

**DIVISION II
CONSTRUCTION AND MATERIAL SPECIFICATIONS
SEWERS**

SECTION 2600 STORM SEWERS

APPROVED AND ADOPTED THIS 17th DAY OF APRIL, 1996

**KANSAS CITY METROPOLITAN CHAPTER
OF THE AMERICAN PUBLIC WORKS ASSOCIATION**

Section	Title	Page No.
2600	<i>Index</i>	<i>i</i>
2600	<i>Blank</i>	<i>ii</i>
2600	<i>Resolution</i>	<i>iii</i>
2600	<i>KCMO Supplement Ordinance Document</i>	<i>iv</i>
2601	GENERAL.....	26-1
2601.1	Description.....	26-1
2601.2	Definitions.....	26-1
2601.3	Specification Modification.....	26-1
2601.4	Revisions of Standards.....	26-1
2601.5	Applicable APWA Standards.....	26-1
2601.6	Cleanup.....	26-2
2602	PIPE SEWER CONSTRUCTION.....	26-2
2602.1	Scope.....	26-2
2602.2	Materials.....	26-2
2602.3	Construction Details.....	26-9
2603	BORING AND JACKING	
2603.1	Scope.....	26-17
2603.2	Materials.....	26-17
2603.3	Construction Details.....	26-18
2604	STRUCTURES.....	26-20
2604.1	Scope.....	26-20
2604.2	Materials.....	26-20
2604.3	Construction Details.....	26-22
2605	OPEN CHANNELS.....	26-24
2605.1	Scope.....	26-24
2605.2	Materials.....	26-24
2605.3	Construction Details.....	26-28
2606	MEASUREMENT AND PAYMENT.....	26-30
2606.1	Measurement.....	26-30
2606.2	Payment.....	26-32

RESOLUTION

Be it resolved by the Director of Public Works of Kansas City, Missouri that the following listed Section of Division II, Construction and Materials Specifications, approved and adopted April 17th, 1996 by the Kansas City Metropolitan Chapter of the American Public Works Association is approved and adopted as Official Standard Construction and Materials Specifications for the Department of Public Works of Kansas City, Missouri with like section and page numbers, except as modified by the replacement pages of the April 1999 KCMO Supplement, the April 2000 KCMO Supplement, and hereby further modified by the replacement pages of the attached supplement.

Section 2600 Construction and Material Specifications for Storm Sewers

A copy of said specifications criteria and supplement are attached hereto and incorporated herein by reference.

The criteria shall become effective May 1, 2007 and shall supersede, in whole page format, all previously adopted Standard Specifications having the same section and page numbers as this supplement replaces. The previously adopted KCMO Supplement pages that are not replaced by the attached specifications criteria and supplement shall remain in effect.

Approved and adopted as Official Document NoCS060102.
This 25th day of April 2007.

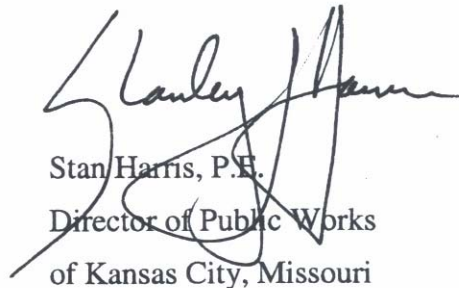

Stan Harris, P.E.
Director of Public Works
of Kansas City, Missouri

KCMO Supplement

Document No.

CITY OF KANSAS CITY, MISSOURI

SUPPLEMENT TO
**APWA STANDARD SPECIFICATIONS AND DESIGN CRITERIA
SECTION 2600**

This is the Kansas City, Missouri Supplement to Section 2600 of the American Public Works Association, Standard Specifications and Design Criteria. The following pages are approved and adopted as replacement pages to the sections and paragraphs of the Kansas City Metropolitan Chapter's APWA, Standard Specifications and Design Criteria (Metro Chapter Standards) that were adopted by the Chapter on April 17th, 1996. The deletions and additions in the following replacement pages that partially revise and supplement the April 1996 Metro Chapter Standards, the April 1999 KCMO Supplement, and the April 2000 KCMO Supplement become a part of Section 2600 for use within Kansas City, Missouri.

Text that supplements the Metro Chapter Standards text is identified by ***bold italic*** font. Text that is found in the Metro Chapter Standards text and that does not appear in the following replacement pages, is deleted and not adopted. The City of Kansas City, Missouri, Department of Public Works supplement replacement pages are identified in the bottom-left margin by “***KCMO (Adoption-Month Adoption-Year)***” and/or by light-blue stock. The supplement replacement pages are numbered and sectioned so as to follow in sequence with the Metro Chapter Standards.

**DIVISION II
CONSTRUCTION AND MATERIALS SPECIFICATIONS
SEWERS**

SECTION 2600 STORM SEWERS

SECTION 2601 GENERAL

2601.1 Description: Storm sewer construction shall consist of furnishing all labor, materials, and equipment necessary for the complete installation of storm sewers and appurtenances in accordance with the Standard Drawings, Contract Drawings, General and/or Supplemental Conditions, specifications and standards referenced herein, and these specifications. Unless otherwise noted within these specifications, the word “sewers” shall refer to pipe sewers, box culvert sewers, or open channels.

2601.2 Definitions: The term “Engineer” whenever referred to in these specifications shall mean the representative of the Governing Agency authorized to determine compliance of the Contractor’s work with the requirements of the specifications as defined in the General and/or Supplemental Conditions.

2601.3 Specification Modification: It is understood that throughout this section these specifications may be modified or deleted by appropriate items in the Special Provisions or notes on the Contract Drawings.

2601.4 Revisions of Standards: When reference is made to a standard specification (ASTM, AWWA, MCIB, and other technical associations), the specification referred to shall be understood to mean the latest revision of said specification as amended at the time of the Notice to Bidders, except as noted on the Contract Drawings or as provided for in the Special Provisions.

2601.5 Applicable APWA Standards: Work incidental to construction of storm sewers shall be performed in accordance with the following APWA Standard Specifications:

Section 2100 Grading and Site Preparation.

Section 2200 Paving and Curbs.

Section 2306 Maintenance of Traffic.

Section 2400 Seeding and Sodding.

2601.6 Cleanup: Cleanup shall follow the work progressively. The Contractor shall remove from the project site all rubbish, equipment, tools, surplus or discarded materials, and temporary construction items.

Streets to be opened to local traffic at the end of the day's operation shall be cleaned of dirt or mud. All equipment and material stockpiles shall be secured for safe passage of vehicles and pedestrians.

Payment, as described in Section 2606, will be made for completed units of work. A completed unit of work included the cleanup and all the other work necessary to complete the unit for payment.

SECTION 2602 PIPE SEWER CONSTRUCTION

2602.1 Scope: This section governs the construction of pipe storm sewers and appurtenances at the location and to the lines and grades indicated on the Contract Drawings.

2602.2 Materials:

A. Reinforced Concrete Pipe:

- 1. Pipe:** Reinforced concrete pipe shall conform to the following ASTM Standards and be of the minimum strength designated herein or such higher strength as may be required by the Contract Drawings or Special Provisions:
 - a. Round Pipe:** ASTM C 76, Class III, Wall B.
 - b. Elliptical Pipe:** ASTM C 507, Class HE-III.
 - c. Arch Culvert Pipe:** ASTM C 506, Class A-III.
- 2. Joints:**
 - a. Flexible Gasket:** Flexible gaskets may be either flat gaskets cemented to the pipe tongue or spigot, O-ring gaskets, or roll-on gaskets. All gaskets shall conform to ASTM C 443.

B. Corrugated Steel Pipe:

1. *Pipe and coupling bands shall conform to the requirements of the following table:*

MATERIAL	SPECIFICATION
<i>Aluminum Coated Coils</i>	<i>(AASHTO) M36 & M274</i>

Circular Culvert Pipe
(2-2/3" x 1/2" corrugations)

<u>Under Roadways or In Street Right-of-Way</u>		<u>Under Railroads</u>		<u>Not Under Railroads</u>	
<u>Diameter</u>	<u>Minimum Thickness</u>	<u>Diameter</u>	<u>Minimum Thickness</u>	<u>Diameter</u>	<u>Minimum Thickness</u>
12-21"	.064"	12-18"	.079"	12-30"	.064"
24-30"	.079"	21-24"	.109"	36-54"	.079"
36-54"	.109"	30-36"	.138"	60-84"	.109"
60-72"	.138"	42-84"	.168"		
84"	.168"				

Circular Culvert Pipe
(3" x 1" and 5" x 1" corrugations)

<u>Under roadways or In Street Right-of-Way</u>		<u>Not Under Roadways</u>	
<u>Diameter</u>	<u>Minimum Thickness</u>	<u>Diameter</u>	<u>Minimum Thickness</u>
36-54"	.079"	36-54"	.064"
60-84"	.109"	60-84"	.079"

Circular Culvert Pipe
($\frac{3}{4}$ " X $\frac{3}{4}$ " X $7\frac{1}{2}$ " spiral rib)

<u>Under Roadways or in Street Right-of-Way</u>		<u>Not Under Roadways</u>	
<u>Diameter</u>	<u>Minimum Thickness</u>	<u>Diameter</u>	<u>Minimum Thickness</u>
12" – 24"	.064"	12" – 42"	.064"
30" – 42"	.079"	48" – 60"	.079"
48" – 66"	.109"	66" – 84"	.109"
72" – 84"	.138"		

Arch Culvert Pipe
(2- $\frac{2}{3}$ " x $\frac{1}{2}$ " corrugations)

<u>Equivalent Diameter</u>	<u>Minimum Thickness</u>	<u>Span*</u>	<u>Rise*</u>
15"	.064"	17"	13"
18"	.064"	21"	15"
21"	.064"	24"	18"
24"	.079"	28"	20"
30"	.079"	35"	24"
36"	.109"	42"	29"
42"	.109"	49"	33"
48"	.109"	57"	38"
54"	.109"	64"	43"
60"	.138"	71"	47"

*Subject to manufacturing tolerances.

Arch Culvert Pipes
(3" x 1" corrugations)

<u>Diameter</u>	Equivalent		Minimum
	<u>Thickness</u>	<u>Span*</u>	<u>Rise*</u>
36"	.064"	40"	31"
42"	.064"	46"	36"
48"	.064"	53"	41"
54"	.079"	60"	46"
60"	.079"	66"	51"
66"	.079"	73"	55"
72"	.079"	81"	59"
78"	.109"	87"	63"
84"	.109"	95"	67"
90"	.109"	103"	71"

* Subject to manufacturing tolerances.

Arch Culvert Pipes
(³/₄" X ³/₄" X 7¹/₂" spiral rib)

<u>Equivalent Diameter</u>	<u>Minimum Thickness</u>	<u>Span*</u>	<u>Rise*</u>
18"	.064"	20"	16"
21"	.064"	23"	19"
24"	.064"	27"	21"
30"	.079"	33"	26"
36"	.079"	40"	31"
42"	.079"	46"	36"
48"	.109"	53"	41"
54"	.109"	60"	46"
60"	.109"	66"	51"
66"	.109"	73"	55"

* Subject to manufacturing tolerances.

All helical pipe shall have circumferential recorrugated ends with a minimum of 4 recorrugations on each *end*. ***The maximum cover depth shall be 30 feet.***

2. Joints: All pipes shall be joined using one of the following methods.

a. Fully Corrugated Hugger Band with Flat Gasket: Coupling bands shall be corrugated for the entire width and constructed of the same gauge and material as the pipe. The dimensions of the band and gasket shall meet the manufacturer's recommendations for the size of pipe being used. A 12 inch wide, 3/8inch thick, one piece, flat gasket shall be centered on the pipe joint before the band is installed. When installed, the band corrugations shall line up the with the pipe end corrugations. The gasket shall be closed cell neoprene meeting ASTM D-1056 grade 2C3 requirements.

b. Hugger Band with O-Ring Gaskets: Coupling bands shall have one annular corrugation on each end and be constructed of the same gauge and material as the pipe. The dimensions of the band and gaskets shall meet the manufacturer's recommendations for the size of pipe being used. One o-ring gasket shall be placed in the first annular corrugation on each side of the pipe joint before the band is installed. The band corrugations shall line up with the second annular corrugation on each pipe end. The o-ring gaskets shall meet the requirements of section 6.9 of ASTM C361.

- C. Vitrified Clay Pipe:** Vitrified clay pipe shall be extra strength vitrified clay pipe and shall conform to ASTM C 700. Compression joints for vitrified clay pipe and fittings shall conform to ASTM C 425.
- D. Ductile Iron Pipe:** Ductile iron pipe shall conform to ANSI/AWWA C151/A21.51 and shall be furnished with standardized mechanical or push-on joints conforming to ANSI/AWWA C1 11/A21.11 Minimum wall thickness shall be Class 50.
- E. High Density Polyethylene Pipe:** *High density polyethylene (HDPE) pipe shall conform to AASHTO M294 Type S. Acceptable pipe must come from a Plastic Pipe Institute (PPI) certified manufacturer and have passed the PPI 3rd Party Certification testing. Each individual section of pipe shall be marked in accordance with AASHTO M294 and shall be affixed with the PPI Certification label. HDPE pipe shall be joined with water tight joints meeting the requirements of AASHTO M294 Paragraph 7.9.3. The maximum cover depth shall be 30 feet.*
- F. Type PSM polyvinyl chloride (PVC) Pipe and Fittings (excluding end-sections):** *Pipe and fittings shall conform to ASTM D2241 except as otherwise specified herein.*
- a. General: Furnish maximum pipe lengths normally produced by the manufacturer except for fittings, closures and specials.*
 - b. Materials: The pipe shall be made of PVC plastic having a cell classification of 12454 B or 12454 C or 13364 B as defined in ASTM D 1784.*
 - c. Design: Pipe shall have an integral bell and spigot joint. Wall thickness shall conform to SDR 21 for ASTM D 2241 pipe. The maximum cover depth shall be 30 feet.*
 - d. Joints: Joint tightness shall conform to ASTM D 3212. Joints shall be push-on type only with the bell-end grooved to receive a gasket. Elastomeric seal (gasket) shall have a basic polymer of synthetic rubber conforming to ASTM F477. Natural rubber gaskets will not be used.*

- G. Granular Bedding Material:** Granular bedding material shall be crushed *clean limestone aggregate meeting one of the following gradations:*

Bedding Material Gradation Limits, % Passing

<i>Sieve Size</i>	<i>3/4"</i>	<i>1/2"</i>	<i>3/8"</i>
<i>1"</i>	<i>100</i>		
<i>3/4"</i>	<i>90-100</i>	<i>100</i>	
<i>1/2"</i>		<i>80-100</i>	
<i>3/8"</i>	<i>20-55</i>	<i>40-70</i>	<i>100</i>
<i>No. 4</i>	<i>0-10</i>	<i>0-15</i>	<i>30-40</i>
<i>No. 8</i>	<i>0-5</i>	<i>0-5</i>	<i>0-4</i>

In areas where the pipe trench is below the potential high point of the water table, only three-eighths (3/8") inch bedding may be used.

- H. Flowable Backfill: Controlled Low Strength Material (CLSM):**

1. Description: This item shall govern the backfilling of *storm sewer* structures and pipe trenches. *When crossing existing utilities, the bedding requirements of the affected Utility shall apply.*

2. Materials:

a. CLSM Control and Quality:

1. Proposed Materials: *No material shall be used until it has been checked or tested for compliance with the specifications of this Section and approved by the Engineer. Representative samples of all materials proposed for use in the CLSM shall be submitted to a private laboratory by and at the expense of the Contractor for compliance testing to these Specifications. All tests shall be performed and all materials shall fully comply. A determination of compliance with these Specifications shall be ascertained by a private laboratory prior to submitting a request for approval to the Engineer for the use of the materials and proposed mix design. Acceptable materials proposed for use shall have test results that accompany the request for approval of the proposed mix design.*

2. **Mix Design Strength Testing:** *Compressive strength shall be tested at 7 and 28 days in accordance with ASTM C- 39. The test cylinders shall be 3 "in diameter by 6 "in height.*

Flowable backfill shall have a maximum and minimum 28-day design compressive strength of 200 psi and 75 psi, respectively. The final set shall be a maximum of 2 hours when tested in accordance with ASTM C 266.

3. **Cost of Testing:** *All tests necessary for determining conformance with the requirements specified herein will be at the Contractor's expense.*

b. CLSM Materials Requirements: *The CLSM materials proposed for use in construction shall conform to the following requirements:*

1. Cement shall *conform to ASTM C 150*, Type I or Type II.
2. Fly Ash shall conform to ASTM C 618, Class C.
3. Fine Aggregate shall *conform to ASTM C 33*.
4. Mixing water shall *conform to ASTM C 94*.
5. *Admixtures shall only be used when specified by the Engineer.*

3. Mixture Design:

The CLSM Flowable Backfill shall be transit mix, or from a mobile mixer. The elapsed time from when the water is added for batching until the CLSM is placed shall not exceed one hour.

The slurry mixture shall be mixed between 70 to 100 revolutions of the ready-mixed truck. To minimize segregation, all flowable fill material shall be re-mixed at the project site at mixing speed in the ready-mix truck for approximately two (2) minutes immediately prior to discharge of the slurry mixture.

The CLSM shall be composed of the proportions as hereinafter provided, or an acceptable mix as approved by the Engineer.

Design Mix	Type A	Type B	Type C
Type 1 Cement	<i>150 lbs.</i>	<i>50 lbs.</i>	<i>0 lbs.</i>
Water	<i>460 (55 gal.)</i>	<i>500 (60 gal.)</i>	<i>542 (65 gal.)</i>
<i>Sand</i>	<i>3085 lbs.</i>	<i>2817 lbs.</i>	<i>2649 lbs.</i>
<i>Class C Fly Ash</i>	<i>0 lb.</i>	<i>250 lbs.</i>	<i>350 lbs.</i>

4. Construction:

The CLSM shall be constructed to the configuration and the lines and grades shown on the Contract Drawings, or as directed by the Engineer.

No CLSM shall be placed on frozen ground. When the ambient temperature either falls or is forecasted to fall below 35 degrees F within 24 hours of its proposed placement time, a set accelerator shall be used.

[THIS SPACE

IS INTENTIONALLY

LEFT BLANK]

2602.3 Construction Details:

A. Trench Excavation: Prior to excavation of the sewer trench in fill areas, fill shall be compacted to a minimum 90% of maximum density (as determined by ASTM D 698) *up* to a minimum *height* of 18 inches above the top of *the proposed* pipe. Trenches shall be excavated to the width and depth as necessary to lay the sewer pipe to the grade line as indicated on the Contract Drawings. Deviation *from the* indicated alignment will not be permitted except under special circumstances, subject to approval of the Engineer. Excavated materials are to be deposited beside trenches and excavations, beyond the reach of slides, transported to the spoil banks, or used for backfilling.

The length of trench excavation opened at one time shall be limited depending on the nature of the soil or other safety considerations. Trenches shall be excavated to a width that will provide adequate working space and pipe clearances for proper pipe installation, jointing, and embedment. However, the limiting trench widths must comply with *the* bedding class requirements *set forth in Section 2602.3.C*. Over-excavation shall be replaced with granular bedding material, *or CLSM*.

- 1. Unclassified Excavation:** Unclassified excavation is defined as the removal of all material encountered regardless of its nature. All material excavated will be considered as Unclassified Excavation unless the Special Provisions specify Classified Materials.
- 2. Rock Excavation:** Rock excavation is defined as the removal of all rock ledges 6 inches or more in thickness, detached rock or boulders having a volume of more than 1-1/2 cubic yards, and shale occurring in its natural state, hard and unweathered.

A rock ledge is defined as a continuous body of rock; which may include interbedded seams of shale or other soft materials. Such interbedded soft material seams less than 12 inches in thickness will be included in the measurement of rock excavation. Such seams 12 inches or greater in thickness will be included only in the measurement of earth excavation.

No soft or disintegrated rock which can be removed with a pick or digging machine, no loose, shaken or previously blasted rock, no broken stones, and no rock which may fall into the trench from outside the limits of excavation will be considered as rock excavation. When solid rock is *unexpectedly discovered* in the trench, it shall be stripped of earth, and the Engineer notified.

When blasting is permitted by the Engineer, the Contractor shall use the utmost care to protect life and property. The Contractor shall comply with all laws, ordinances, and applicable safety code requirements and regulations relative to the handling, storage and use of explosives and protection of life and property, and shall be responsible for all damage thereto caused by *their* or *their* subcontractor's operations.

The Contractor shall provide insurance as required by the General Provisions and Covenants and Special Provisions before performing any blasting. The governing agency shall be notified at least 24 hours before blasting operations begin.

3. **Earth Excavation:** Earth excavation is defined as the removal of all material not defined as rock.
4. **De-watering:** The Contractor shall remove any water that may accumulate, or be found in the trenches and other excavations made under the Contract.

The Contractor shall form all dams, flumes or other works necessary to keep them clear of water while the sewers and their foundations, and other foundation works, are being constructed. All water shall be removed from such excavation in a manner to avoid damage to property.

5. **Cribbing and Sheeting:** The Contractor shall furnish, install, and maintain such sheeting, bracing, and other components, as may be required to support any excavation and to prevent any movement which could in any way injure or delay the work or endanger adjacent pavement, building, or other structures. Care shall be taken to prevent voids outside of the sheeting, but if voids are formed they shall be immediately filled and consolidated.

For the purpose of preventing injury or property damage, contractor may leave in place all sheeting or bracing, and other items to be embedded in the backfill of the trench. No sheeting or bracing, however, shall be left in place within 5 feet of the surface without the written permission of the Engineer.

- 6. Unstable Foundation:** Where materials encountered in the bottom of the trench are deemed as unsuitable by the Engineer to afford a sufficiently stable pipe foundation, the materials shall be removed to the depth and limits as ordered by the Engineer. Areas undergraded shall be backfilled with approved granular material or materials meeting the requirements of Section 2102.5 entitled "Undergrading."
- 7. Protection of Property:** The Contractor shall satisfactorily shore, support, and protect any and all structures and all pipes, sewers, drains, conduits, and other facilities, and shall be responsible for any damage resulting thereto. The Contractor shall not be entitled to any damages or extra pay on account of any postponement, interference, or delay caused by any such structures and facilities being on the line of work, whether or not they are shown on the Contract Drawings; specifically, but not limited to, damage due to delay in utility relocation.

B. Laying and Jointing:

- 1. Handling and Protection:** All pipe shall be protected during installation against shock and free fall, and be installed without cracking, chipping, breaking, bending, or damage to coating materials. Damaged pipe materials shall be replaced with new materials except as may be permitted by the Engineer.
- 2. Grade Control:** Maximum deviation from indicated alignment of any pipe after installation and backfilling shall not be greater than 0.1 foot. All pipe shall have a continuous slope free from depressions that will not drain. The Contractor shall establish such grade control devices as are necessary to maintain the above tolerances.
- 3. Laying:** The laying of pipe in finished trenches shall commence at the lowest point, and pipe shall be installed with the bell end forward or upgrade. All pipe shall be laid with ends abutting and true to line and grade. Pipe shall be carefully centered to form a sewer with a uniform invert.
- 4. Bedding:** The class of bedding required shall be as indicated on the Contract Drawings or standard details except that as a minimum the bedding shall be granular bedding material placed to the requirements of Section 2602.3.C. Bedding shall be rodded, spaded, and consolidated as necessary to provide firm uniform support for the pipe, and not subject pipe to settlement or displacement.

5. **Jointing:** Preparatory to making *filled, bonded, and watertight sealed* pipe joints, all surfaces of the portions of the pipe to be jointed shall be clean and dry. Lubricants, primers, adhesives, and other substances that are used shall be compatible with the jointing material recommended or specified.

Other than for trimming sewer pipe to be flush with the inside walls of storm sewer structures, no pipes may be trimmed unless ordered by the Engineer. Pipes having defects that do not cause their rejection shall be so laid as to place these defects where they will be of least consequence.

Trenches shall be kept water-free and as dry as possible during bedding, laying, and jointing, and for as long a period as required to protect the pipe joints and concrete in structures.

As soon as possible after the joint is made, sufficient bedding material shall be placed alongside each side of the pipe to offset conditions that might tend to move the pipe off line and grade.

- a. **Concrete Pipe Flexible Gaskets:** Flat gaskets may be cemented to the pipe tongue or spigot. O-ring gaskets shall be recessed in a groove on the tongue or spigot and confined by the bell or groove after the joint is completed. Roll-on gaskets shall be placed around the tongue or spigot and rolled into position as the joint is assembled. Flat gaskets and O-ring gaskets shall be lubricated as recommended by the manufacturer.
- i. *Flat gasket: Flat flexible gaskets shall conform to ASTM C 443. If there is no recess provided for the gasket, the surface of the tongue shall be cleaned and rubber adhesive applied. Using quick-drying adhesive, gaskets may be applied ahead of the laying operation or in the plant.*
 - ii. *O-ring gasket: O-ring or roll-on flexible gaskets shall conform to ASTM C 361, Section 4.10. The entire surface of the bell that comes in contact with the rubber gasket shall be well lubricated with a soap lubricant. The entire gasket shall be greased with soap. Only the soap lubricant supplied by the pipe manufacturer shall be used. Adhesive type cements shall not be used.*

- b. Corrugated Steel Pipe:** Corrugated steel pipe shall be assembled and installed in accordance with the manufacturer's instructions and in conformance with the latest edition of Section 26, entitled "Metal Culverts," Division II, AASHTO Standard Specifications for Highway Bridges. In case of a discrepancy between this specification and AASHTO Section 26 or the manufacturer's instructions, this specification shall govern.

Canvas or nylon slings (or something comparable that will not damage the pipe coating, i.e., appropriate lifting lugs) shall be used for all pipe handling. Pipe shall not be rolled or dragged over gravel or rock and shall be prevented from striking rock or other hard objects during placement in trench or on bedding.

Corrugated steel pipe shall be placed on the bedding material starting at the downstream end. Pipes with circumferential seams shall be installed with their inside circumferential sheet laps pointing downstream.

Gaskets shall be furnished in accordance with *these specifications*, Contract Drawings and Special Provisions.

In addition to this and prior to acceptance, the culvert shall be free of any dents greater than ½ inch and shall pass a deformation test. This test shall be performed by the Contractor to ensure that the geometric inner specified dimensions of the entire culvert are not deformed by more than 5%. Any part of the culvert that does not meet these requirements shall be replaced or repaired by the Contractor at no additional cost to the City.

Corrugated steel pipe shall not be placed under arterial streets as defined in section 5202.

Corrugated steel pipe 60" or larger placed under collector streets shall not be placed in more than 6' of fill. Collector streets are defined in section 5202.

Corrugated steel pipe shall not be placed in permanent dams. A dam is defined in 5603.3.

For pipe sizes 48 inches and larger, during pipe installation, including placement and consolidation of the rock bedding and backfill to a point 4 feet above the top of the pipe, full time inspection shall be provided by a qualified inspector working under the supervision of a professional engineer. After installation and prior to acceptance, certification by a Missouri Registered Professional Engineer is required and shall state that the installation and backfill conforms to the pipe manufacturers recommendations and the Standard Specifications and Design Criteria of the City of Kansas City, Missouri. Cost of this inspection and certification shall be borne by the Contractor.

During construction of the project in areas subjected to heavy construction equipment traffic, pipe sizes 12" - 42" shall have a minimum cover of 3 feet, and pipe sizes 48"-120" shall have a minimum cover of 4 feet. Full time inspection for this fill shall be provided by a qualified inspector working under the supervision of a professional engineer who is registered in the State of Missouri. Certification shall be provided as explained in the previous paragraph.

- c. *HDPE Pipe: HDPE pipe shall be assembled and installed in accordance with the manufacturer's instructions. For pipe sizes 48 inches and larger, during pipe installation, including placement and consolidation of the rock bedding and backfill to a point 4 feet above the top of the pipe, full time inspection shall be provided by a qualified inspector working under the supervision of a professional engineer. After installation and prior to acceptance, certification by a Missouri Registered Professional Engineer is required and shall state that the installation and backfill conforms to the pipe manufacturers recommendations and the Standard Specifications and Design Criteria of the City of Kansas City, Missouri. Cost of this inspection and certification shall be borne by the Contractor.*

During construction of the project in areas subjected to heavy construction equipment traffic, pipe sizes 12" - 42" shall have a minimum cover of 3 feet, and pipe sizes 48"-120" shall have a minimum cover of 4 feet. Full time inspection for this fill shall be provided by a qualified inspector working under the supervision of a professional engineer who is registered in the State of Missouri. Certification shall be provided as explained in the previous paragraph.

- d. Structure Connections:** Pipes connected to structures shall be cut parallel with the inside face of the structures. Projection of the pipe beyond the inside face shall not exceed 1 inch (measured at the springline for structures having curved walls.)

[THIS SPACE

IS INTENTIONALLY

LEFT BLANK]

C. Backfill of Trenches:

General: All trenches and excavations shall be backfilled with suitable material placed and compacted in conformance with this Section and Section 2102.6 entitled "Embankment."

The bedding material area identified as Zone "A" in Figures "1" through "3" in this Section shall consist of approved granular material for all storm sewer conduits. The bedding rock shall be consolidated by vibratory or manual "chinking" action to provide uniform support – beneath and up to the Springline of the conduit.

In the areas above Zone "A", the placement, consolidation, compaction, and moisture content of all backfill materials shall be done in accordance with the following specifications and cross-section details of Figures "1 thru 4." Controlled low strength material (CLSM), or flowable fill as it is commonly known, is the preferred backfill material for all trenches under street or alley pavements up to the level of the pavement subgrade. The pavement subgrade is a six to twelve-inch thick layer that consists of uniformly compacted material (as specified in Section 5200 and the Standard Drawings).

Figure 1: The cross-sectional details in Figure "1" describe the minimum requirements for trench backfilling in areas within street and alley pavements that are located in deep (greater than 30" of cover) areas. The backfill shall be placed in accordance with section 2102.6.B.

Figure 2: The cross-sectional details in Figure "2" describe the minimum requirements for trench backfilling in areas within street and alley pavements that (1) do not allow for placement of the backfill material in accordance with 2102.6.B or (2) located in shallow (30" to 18" from top of pipe to bottom of pavement) roadway trenches.

Figure 3: The cross-sectional detail of Figure "3" prescribes the minimum requirements for trench backfilling in areas that are outside of street and alley pavements. The requirements of Figure "3" may also be used in areas located within street or alley pavements – only when a developer surety in the form of a Maintenance Bond or irrevocable Letter of Credit (L.O.C.) agreement, in the name of the Developer and specific to a particular project, is in effect between the Developer (or current Landowner) and the Director of Public Works. The Maintenance Bond or L.O.C. agreement must reflect the requirements contained within this Section and in accordance with our standard

Maintenance Bond or L.O.C. agreement forms. The Maintenance Bond or L.O.C. Agreement shall be in the minimum amount of \$10,000, or \$200 per lot, whichever is greater. When allowed by separate ordinance or other provision to post a single Developer Bond or L.O.C. surety for multiple projects, said surety required shall not exceed a maximum of \$30,000. The term shall be a minimum of three years, and shall commence on the date of acceptance of the permit work, specified as the expiration date of the permit by the Director of Public Works. In the event the permit expires before the work is accepted, the Contractor shall apply for reissuance of the permit to establish a new permit expiration date. A Contractor is not authorized to continue work under an expired permit. Additionally, where L.O.C.'s are the form of surety under this provision, the Developer or Landowner shall amend said surety when applying for reissuance to reflect the revised permit expiration date and commencement date of the surety's 3-year maintenance period. In the event that street pavement repair work becomes necessary and monies are withdrawn from the Bond or Letter of Credit to effect the repair work, the Bond or L.O.C. shall be replenished by the Developer, and the term of the Bond or L.O.C. shall be reissued to commence upon completion and acceptance by the Director of Public Works of the repair work performed. The City reserves the right to withhold approvals under this provision from other Developer projects subject to a review of all outstanding claims under this provision. Acceptance of the street construction by the Director of Public Works shall not constitute conveyance of maintenance responsibility from the Developer Bond or L.O.C.

Developer Repair Bond or Letter of Credit: When the Developer or Landowner chooses not to use CLSM as the backfill material in Zone "B" for conditions set forth in Figures "1" and "2," the Developer must perform the work as set forth in Figure "3" and must post an irrevocable Letter of Credit or a Maintenance Bond. The Bond or L.O.C. shall be written to ensure the repair of any street pavement settlements that occur at the location of storm sewer, sanitary sewer, waterline mains, or dwelling service lines for same, as a result of construction, upon due notice (as outlined in the specifications stated herein) at all locations. The Letter of Credit or Maintenance Bond will be invoked by the Director of Public Works after a period of 120-days from the date of initial notification to the Contractor of a street settlement, and where there is inaction in effecting a street repair - as outlined in Standard Drawing SR-1, including minimum requirement modifications stated herein - (1) within thirty days of initial notification on the part of the Developer's Contractor to respond with a commitment and schedule of repair that complies with the 120-day grace period for affecting the repair, and (2) after there is non-response by the Contractor to produce a timely schedule, the Contractor's Bonding Company is formally notified, and the repairs are not completed within 120-days of the initial notification to the Contractor.

Minimum Repair Requirements: The repair of any street pavement settlements at the location(s) of storm, sanitary, waterline crossings, or service lines for same that were initially constructed under the specifications outlined in Figure "3" of this Section shall be done in accordance with Standard Drawing SR-1 under the field supervision of (1) an independent testing laboratory who provides certification that the repairs were done in accordance with Section 2600 and Standard Drawing SR-1, or (2) a representative of the Director of Public Works who shall have prescriptive authority over the intervals and amounts of nuclear density testing outlined herein.

Two nuclear density compaction and moisture content tests shall be done at the direction of the field supervisor upon excavation of the entire trench settlement area to a minimum depth of between four feet and one-half the depth of the conduit. The ultimate minimum depth shall be dependent on the soil conditions encountered during excavation. If testing of the underlying material at the required minimum depth reveals that the material is unsuitable, excavation shall continue until compaction and moisture testing confirms that suitable materials have been reached - or the top of pipe is encountered, whichever occurs first. A minimum of two nuclear density moisture and compaction confirmation tests shall be performed before backfilling.

In choosing the backfill materials, the Contractor may (1) treat the excavated (native) materials to attain optimum moisture content, (2) bring-in suitable materials from offsite that are of optimum moisture content, or (3) use CLSM. All non-CLSM backfill material shall be placed in compacted lifts not to exceed twelve inches for soil or six inches for soil and rock. Clean rock or a rock and dust mixture having a gradation similar or less than that described for untreated compacted aggregate in these specifications shall not be considered suitable material.

Two nuclear density compaction and moisture content tests shall be done at the direction of the field supervisor at a level that is half the distance up from the bottom of the newly excavated trench - whenever non-CLSM backfill material is used. A final set of tests shall be done at the top of subgrade. Any test that reveals that the materials do not comply with the requirements set forth in Figures "1" thru "3" shall be re-excavated to a level half the distance to the bottom of the trench, and another set of tests shall be done to confirm compliance.

All testing shall be arranged and paid for by one of the following firms and in the following precedence, as events progress and actions (or inaction) unfold: (1) the Contractor, (2) some other contractor as may be hired by the Contractor's Bonding company, (3) some other Contractor as may be hired by the Developer when there is a Bond or Letter of Credit Agreement/arrangement with the Director of Public Works, or (4) some other contractor as may be hired by the Developer's Bonding Company.

1. **Backfilling under street and alley pavements in deep (30" minimum cover over pipe) areas where heavy compaction equipment is utilized.**

Backfilling shall be placed as shown in *Figure 1*.

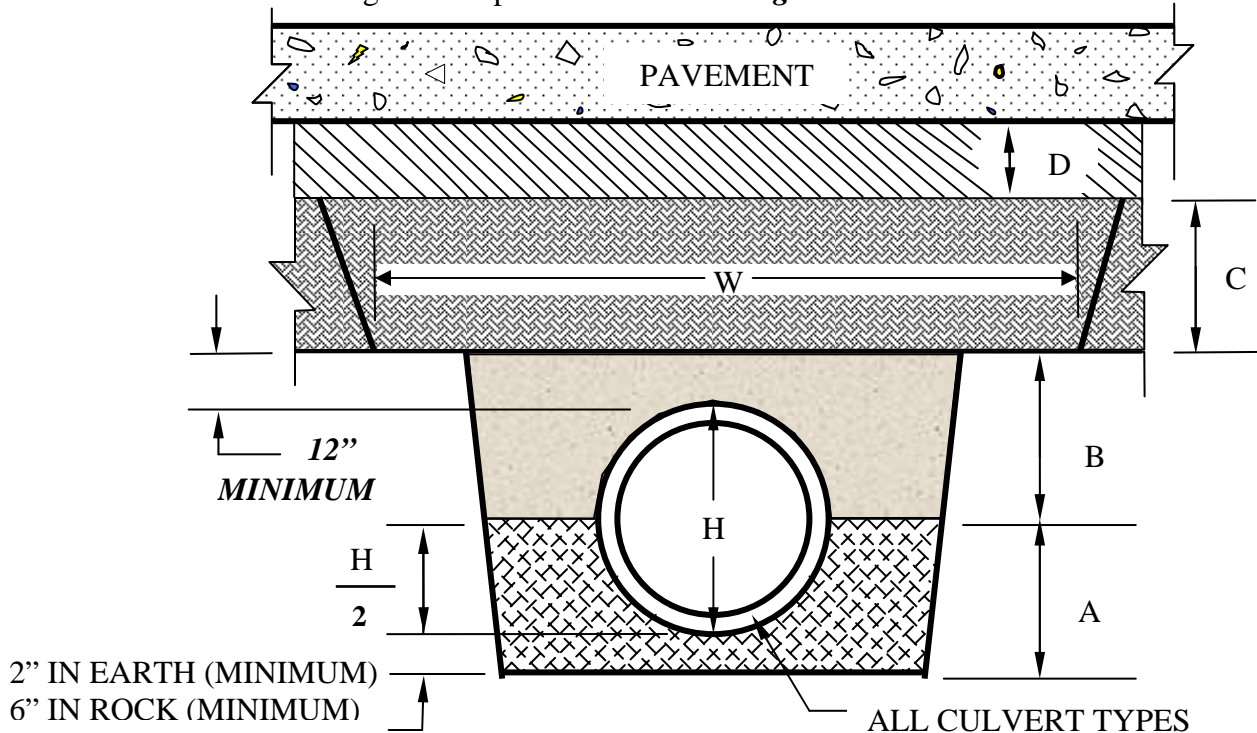

A – *Consolidated* granular bedding material.

B – Flowable Fill (CLSM).

C – *Compacted Embankment* - Shall be constructed in accordance with Section 2102.6. Lift thickness shall not exceed the capability of the equipment being utilized to achieve the proper density and consolidation, and in no case shall a lift exceed twelve inches for soil. The minimum width, W , shall be two feet wider than the width of the required compaction device, or five feet, whichever is greater.

D – *Compacted Subgrade* - Subgrade thickness shall be as specified in Table 1 of Section 5206 and as directed by the engineer. Subgrade preparation shall be done in accordance with Section 2201 and shall consist of untreated compacted aggregate, stabilized aggregate base, or compacted soil – in accordance with the associated Sections 2201, 2202, and 2203.

FIGURE 1
(Deep Sewer Lines Using Earth Compaction Equipment,
or in Depths Exceeding 30" of Cover)

2. The following cross-sectional view of typical storm sewer trench construction under street and alley pavements, Figure 2, shall apply to all storm sewer backfill areas where deep trenches are not widened to allow heavy roadway compaction equipment. Figure 2 shall also apply to shallow (30" to 18" from top of pipe to bottom of pavement) roadway trenches:

Backfilling shall be placed as shown in *Figure 2*.

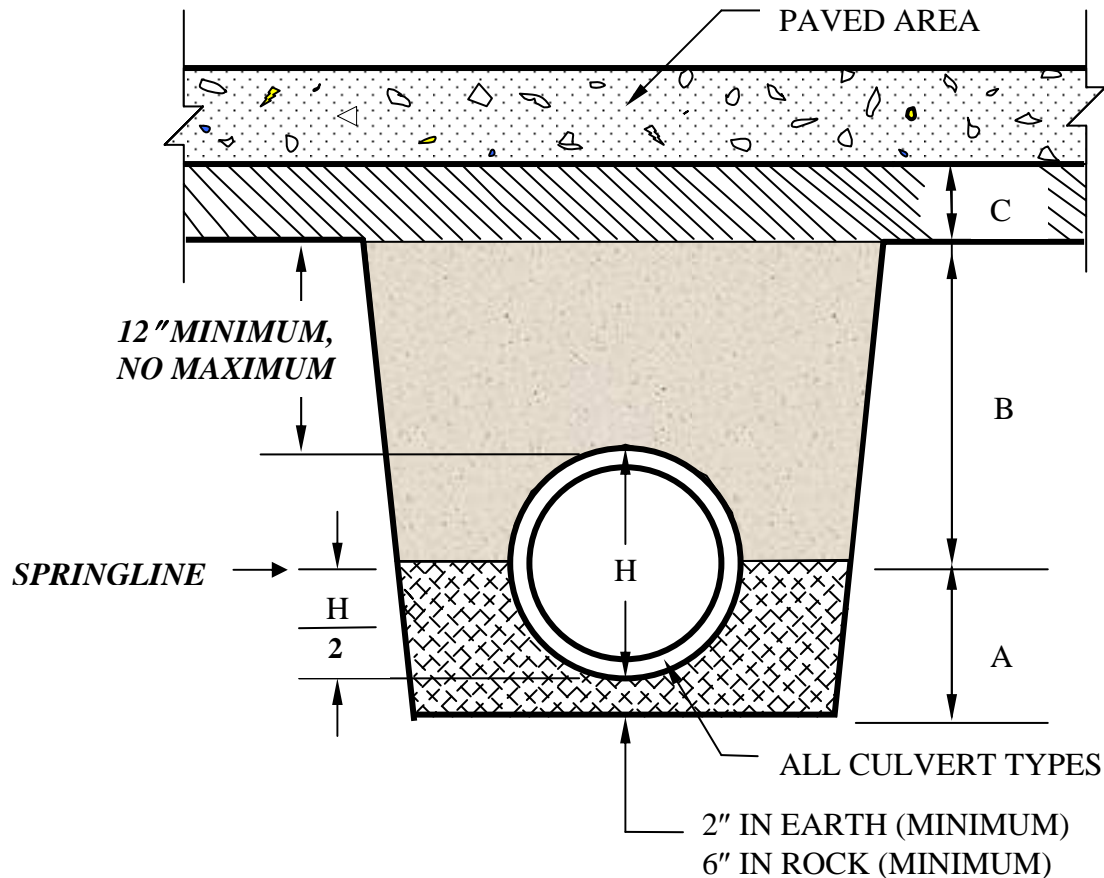

A – *Consolidated* granular bedding material.

B – Flowable Fill (CLSM).

C – *Compacted Subgrade* - Subgrade thickness shall be as specified in Table 1 of Section 5206 and as directed by the engineer. Subgrade preparation shall be done in accordance with Section 2201, and shall consist of untreated compacted aggregate, stabilized aggregate base, or compacted soil – in accordance with the associated Sections 2201, 2202, and 2203.

FIGURE 2

(For Deep Trenches Without Roadway Compaction Equipment,
or Shallow Trenches Having Less than 30" of Cover)

[THIS SPACE

IS INTENTIONALLY

LEFT BLANK]

- 3. Trench backfilling in areas other than street and alley pavements where the near edge of trench is behind the back of curb:***

Backfilling shall be placed as shown in *Figure 3*.

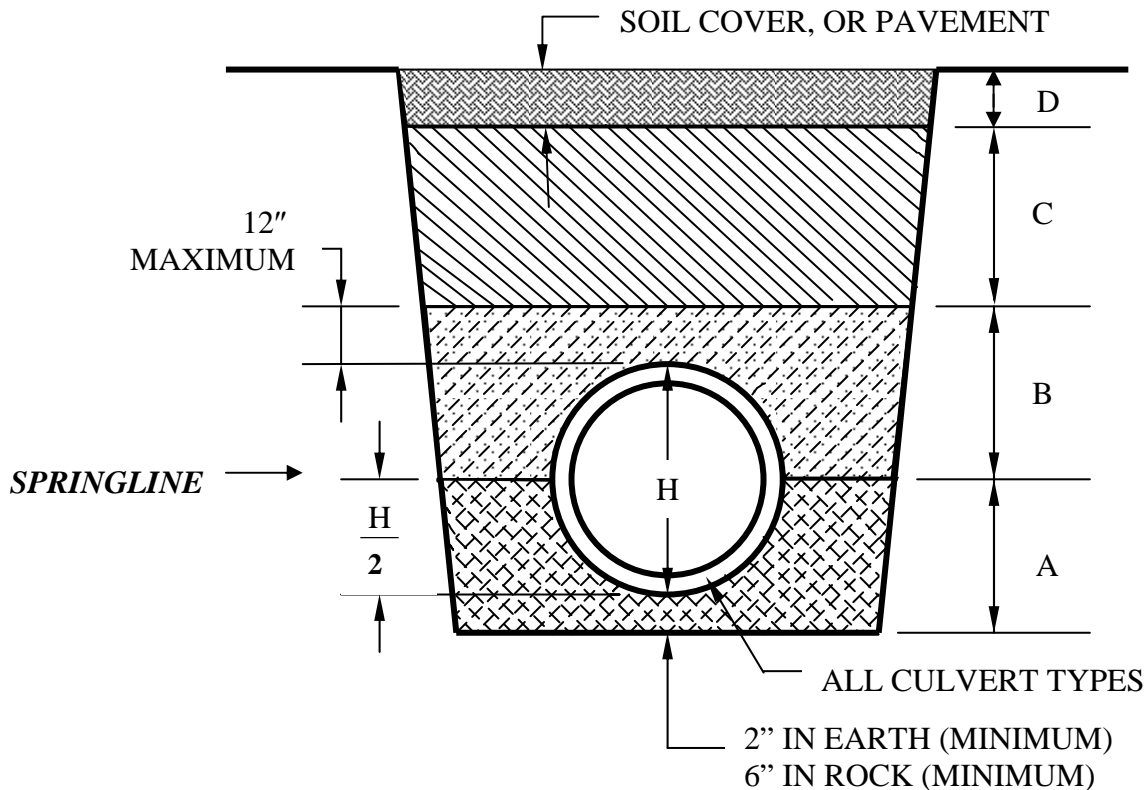

A – *Consolidated* granular bedding material.

B – *Consolidated* granular bedding material, *flowable fill (CLSM)*, or compacted soil – *compacted to 90%* of maximum density using ASTM D 698. Maximum lift thickness *for the granular or soil materials shall be six inches*.

C – *Untreated compacted aggregate, flowable fill (CLSM)*, or compacted soil – compact to approximate density of adjacent soil but not less than 90% of maximum density using ASTM D 698, *except in the Central Business District, as defined in section 2209.2, where untreated compacted aggregate shall not be used. Lift thickness shall not exceed the capability of the equipment being utilized to achieve the proper density and consolidation; however, in no case shall it exceed twenty-four inches for soil*.

D – *Soil Cover* – Soil cover shall be as specified in Section 2102.7. The top twelve inches shall be consolidated soil; the top six inches shall be topsoil suitable for sustaining grass.

FIGURE 3
(Trenches Outside of Street Pavements, or
Inside Street Pavements With Special Bonding Established)

[THIS SPACE

IS INTENTIONALLY

LEFT BLANK]

SECTION 2603 BORING AND JACKING

2603.1 Scope: This section governs construction of steel casings, complete with bulkheads and sand fill, by boring and/or jacking at the locations and to the line and grades indicated on the Contract Drawings, or where constructed at the Contractor's option, when approved, to bypass obstructions without open cutting.

2603.2 Materials:

A. Steel Casing:

1. Steel casing for bored or jacked construction shall conform to ASTM A 139.
2. Steel shall be grade B under railroads and grade A for all other uses.
3. Minimum wall thickness for steel casing shall be in accordance with the following table:

<u>Diameter of Casing</u>	<u>Under Railroads</u>	<u>All Other Uses</u>
24"	0.406"	0.281"
26"	0.438"	0.281"
28"	0.469"	0.312"
30"	0.469"	0.312"
32"	0.500"	0.312"
34"	0.500"	0.312"
36"	0.500"	0.344"

4. Casing joints shall be welded by a certified welder in accordance with ANSI/AWWA C 206.

B. End Seals: End seals shall be brick conforming *to* Section 2604.2.F of these specifications. Mortar shall comply with Section 2604.2.G of these specifications.

C. Sand Fill: Sand fill shall comply with ASTM Designation C 33 or MCIB Section 4, Fine Aggregate. Moisture content of the sand shall not exceed 0.5%.

2603.3 Construction Details:**A. Boring and Jacking:**

1. Prior to starting to work, complete details of the methods and the liner material to be used shall be submitted to the Engineer for approval.
2. The maximum allowable deviation from indicated alignment and grade shall be as follows except when altered by the Contract Drawings or Special Provisions:
 - a. Alignment.....1.0%
 - b. Grade.....1.0%

B. Casing Installation:

1. The steel casing shall be advanced in a continuous operation without interruption. Sections of the casing pipe shall be welded together to form a continuous conduit capable of resisting all stresses, including jacking stresses. the casing in its final position shall be within alignment and grade tolerances specified in Section 2603.3.A.2. There shall be no space between the earth and the outside of the casing. Any voids which do occur shall be filled by pressure grouting.
2. Boring operations shall be performed by experienced crews using a rotary type boring machine designed especially for this purpose. Boring shall be performed in a manner to prevent disturbing the overlying and adjacent materials.
3. **Jacking:**
 - a. Jacking frame, guides, blocking, head, and reaction devices shall be arranged to apply uniform pressure about the casing circumference without damage to the casing material, and to maintain alignment within specified tolerances.
 - b. Jacking reaction device shall provide adequate resistance to withstand 200 percent of the maximum jacking pressure.
 - c. Provide jacks of adequate number and size for the required jacking pressure; but not less than two jacks.

- d. Maintain jacking pit and pipe installation in such condition that drainage does not accumulate. Control and disposition of surface and subsurface water at the site of jacking operations shall be the Contractor's responsibility.
 - e. Excavation at the heading shall not be extended more than 1 inch outside the top and sides (upper 300-degree sector) of the casing and shall be true to grade at the invert (lower 60-degree sector).
 - f. Once jacking begins, it shall proceed without interruption until installation of the entire length of the jacked casing is complete.
- 4. Excavation in Jacked Casings:** Perform excavation within jacked casings by hand or machine methods as necessary to remove the materials encountered without disturbing the overlying material. The jacked casing shall be advanced a sufficient distance ahead of the excavation face and/or shield used as necessary to protect the workman and the work, and to prevent the uncontrolled entry of unstable materials into the casing.
- 5. Unstable Materials:** If materials are encountered during casing installation that cannot be excavated safely or without creating voids around the exterior of the casing, the Contractor shall discontinue casing installation and stabilize such materials by dewatering, chemical soil stabilization, grouting, or other methods, and/or modify equipment and procedures as necessary to complete the casing installation.

C. Sewer Pipe Installation:

1. Pipe shall be placed inside the casing to the indicated line and grade by the use of wood skids or other equivalent methods. The wood shall be pressure treated with creosote, pentachlorophenol, or salt-type preservative in accordance with AWWA C2. Cut surfaces shall be given 2 heavy brush coats of the same preservative. The wood skids shall be securely fastened to the sewer pipe with steel straps.
2. End seals shall be constructed after the sewer pipe is installed and approved.
3. The annular space between the casing and sewer pipe shall be filled with sand blown-in so that all space is filled without disturbing the alignment and grade of the sewer pipe. *Flowable fill of mix design meeting Section 2602.3, Type A, B, or C may be substituted in lieu of sand fill.*

SECTION 2604 STRUCTURES

2604.1 Scope: This section governs the performance of all work necessary for construction of cast-in-place and precast concrete structures for inlets, manholes, junction boxes, box culverts, headwalls, and incidental structures. Masonry structures shall not be allowed under these Specifications.

2604.2 Materials:

A. Concrete Mixes: Concrete shall be MCIB Mix Number A564-3/4-4 or A543-1-4 at the Contractor's option; except concrete used for soil stabilization, pipe cradles, filling, leveling courses, and other similar purposes may be either MCIB Mix Number A440-3/4-4 or A473-1/2-4. *Using a mechanical mixer, concrete may be prepared on-site to construct inverts only for pre-cast structures having developed bases. Concrete may be either MCIB Mix Number 495-3/4-4 or 527-1/2-4 at the Contractor's option. A maximum of 7 gallons of water per sack of cement is in the design for both of these mixes.*

B. Concrete Materials:

1. Concrete materials shall conform to MCIB Specification Section 4 entitled "Materials," except that total shale, coal, and lignite content shall not exceed 0.5 percent by weight, and clay content shall be zero. *Coarse aggregate shall be Bethany Falls limestone or approved equal.*
2. Concrete shall conform to all requirements of MCIB Section 5 entitled "Concrete Mix Design Table," and the compressive strength of each mixture shall be as designated therein.

C. Reinforcing Steel: Reinforcing bars shall conform to ASTM C 615, Grade 60. Welded steel wire fabric shall conform to ASTM A 185.

D. Precast Concrete Structures:

1. **Manholes:** Precast manholes shall conform to ASTM C 478. *Manholes are classified by their inside diameter dimension, and shall conform to the dimensions indicated on the Contract Drawings.*
2. **End Sections:** End sections for concrete pipe shall be flared end sections of the pipe manufacturer's standard design, and shall meet all applicable requirements of ASTM C 76 for Class II or higher classes of pipe.
3. **Rectangular Structures:** Rectangular structures shall conform to the dimensions indicated on the Contract Drawings and be designed for the following loads:

- a. H-20 live load for all structures in/or under pavement, shoulders, driveways, and other traffic areas.
- b. 2,000-lb wheel live load for curb opening inlets and junction boxes in non-traffic areas.
- c. 50-pcf equivalent fluid pressure for soil pressure on vertical walls.
- d. 120 pcf for unit weight of soil cover on top slabs.

4. **Joints:** Joints between concrete structures shall be *filled* with plastic joint compound or preformed plastic compound *as stated herein*.

a. **Barrel Sections:** Minimum cross sectional area of preformed compound between concrete *barrel* sections shall be 1 inch square or 1.25 inches diameter. *Minimum cross-sectional area of the preformed compound between the concrete adjustment ring and the cone barrel section shall be two beads of either 1 inch square or 1.25 inches in diameter.*

b. **Manhole Adjustment Rings:** Rings shall be constructed of concrete, HDPE, or recycled rubber.

If HDPE adjustment rings are used, they shall be injection molded-recycled HDPE - as manufactured by LADTECH, Inc. or approved equal. They shall be bolted to the manhole cone section and otherwise installed as per manufacture's recommendations.

If recycled rubber adjustment rings are used, they shall consist of no less than 80%, by weight, recycled rubber and no less than 10% by volume shredded fiber as manufactured by GNR Technologies or approved equal. They shall be installed as per manufacture's recommendations.

The top and bottom of all adjustment rings shall be sealed using a mastic filler meeting the requirements of 2510.3.11 or an epoxy paste. The epoxy paste shall be a two component, moisture insensitive, containing no solvents, and capable of bonding with all materials it is to be used on, like Epoxytec Micor C.P.P or approved equal. Minimum cross-sectional area of preformed compound between concrete adjustment rings shall be two beads of either 1 inch square or 1.25 inches in diameter.

- c. Brick and Mortar Riser Adjustments: Brick and mortar used to adjust height and/or pitch of a manhole ring casting in paved areas shall have an external rubber seal. The rubber seal shall extend from the casting ring to the cone barrel section and shall band the external face of the brickwork.*
- d. Manhole Ring and Covers: Minimum cross-sectional area of preformed compound between the concrete adjustment ring and the manhole casting shall be two beads of either 1 inch square or 1.25 inches in diameter.*
- e. Internal Manhole Chimney Frame Seal: Internal frame seal shall consist of a flexible rubber sleeve, interlocking adjustment extension(s), and stainless steel compression bands. The flexible rubber sleeve and extension shall be extruded or molded from a high grade rubber compound conforming to the applicable requirements of ASTM C 923 with a minimum tensile strength of 1500 psi and minimum elongation at break of 350%. At a minimum, the compression bands shall be 16-gauge stainless steel conforming to ASTM A 240, Type 304, with a minimum width of one inch. Screws, nuts, and bolts shall be stainless steel conforming to ASTM F 593 and 594, Type 304. The compression bands shall have the capacity to tighten with enough pressure to make a watertight seal around the rubber chimney sleeve.

[THIS SPACE

IS INTENTIONALLY

LEFT BLANK]

- E. Air Entrainment:** All concrete, *unless otherwise stated in* Section 2604.2.A *or 2602.2G*, shall be air entrained. Minimum strength requirements shall be as specified in Section 2604.2.B.2 above.
- F. Brick:** Brick shall conform to ASTM C 32, Grade SM, free from cracks and checks, and emit a metallic ring when struck with a hammer.
- G. Cement Mortar:** Pre-mix mortar non-shrink or expansive grout in mortar for packing pipe in openings of precast structures, setting castings, and other incidental work shall consist of one part Portland cement and two parts sand by volume mixed with sufficient water to form a workable stiff grout

H. Manhole Castings:

- 1. Rings and Covers:** Castings shall be gray iron conforming to ASTM A 48, Class 35B. Castings *of rings and covers* shall be of the shape, dimension, minimum weight, *and type as* indicated on *Standard Drawing "MH-RC (M),"* and be free from manufacturing defects. *All curb inlet castings shall have cam locks.* If requested by special order, castings shall be cleaned and painted with one coat of tar prior to delivery. Bearing surfaces between all rings and covers for installation in all areas shall be machined to provide even seating *and interchangeability of like pieces.*

All manhole rings and covers placed in paved areas or as directed by the Water Services Department Engineer shall be adjustable to meet any slope and grade of the roadway, from 0 to 17%, and shall be able to be raised or lowered in ¼ inch increments, up to 2¾ inches. Ring height must be adjustable after installation without disturbing the surrounding pavement. The ring and lid shall be rated for H20 traffic. Cam lock covers shall not be placed in roadway pavement unless shown on the plans or directed by the engineer. All covers shall have provisions for opening, such as concealed pick holes.

- 2. Steps:** *All steps shall comply with Section 2510.3.8.b(2) and the most recent Supplement to Section 2500. Cast iron steps shall not be used.*

- I. Steel End Sections:** Steel end sections shall be fabricated from galvanized *or aluminized* base metal as specified in Section 2602, and shall be flared end sections of the metal pipe manufacturer's standard design. End sections shall be furnished with a steel toe plate. Bituminous coating is not required.

- J. Toe Walls:** Flared end sections for concrete and steel pipe shall be set on a concrete toe wall centered on the end of the section. Toe walls shall be 8 inches thick by 24 inches deep by the width of the *bottom of the cut trench*.

Section 2604.3 Construction Details:

- A. Concrete Structures:** Concrete construction shall conform to the following MCIB Standard Specifications:

Section 8 - Placing of Concrete
 Section 9 - Curing and Protection
 Section 10 - Cold Weather Concrete
 Section 11 - Hot Weather Concrete
 Section 13 - Forms
 Section 24 - Finishing
 Bulletin 6 - Concrete Inspection
 Bulletin 12- Reinforcing Steel –
 Handling and Placing

- 1. Precast Structures:** The Contractor may, at his option, construct precast concrete inlets, junction boxes, and box culverts, in lieu of the cast-in-place structures indicated on the Contract Drawings; except that all concrete base slabs for pre-cast inlets, manholes, and junction boxes may be cast-in-place. Solid concrete brick or block shall be used to block inlets and similar structures to grade during placement of base slab concrete.

Precast concrete box culvert sections shall be installed on a 4-inch leveling course of untreated compacted aggregate conforming to Section 2202. Leveling courses shall extend 1 foot past the line of the box section, and be finished to a true plane surface to provide uniform bearing for the precast section.

- 2. Finishing:** *Exposed edges of all slabs, walls, and other concrete structures shall be beveled 3/4" or edged with a 1 1/4" radial tool.*
- a. Formed Surfaces:** Immediately following removal of forms, fins and irregular projections shall be removed. Form tie connections, holes, honeycomb spots, and other defects shall be chipped to ensure the voided area is exposed, and shall be chipped back to solid material. These areas shall be thoroughly cleaned, saturated with water, and pointed with a grout approved by the Engineer. The repaired surfaces shall be cured in accordance with MCIB Specification Section 9.
- b. Exposed Slabs:** Finish for exposed slabs shall be wood float texture in accordance with MCIB Specification Section 24.

- 3. Form Removal:** Forms shall remain in place until the concrete has attained sufficient strength to support loads imposed by backfilling, construction, and traffic. *Within 24 hours of form removal, small holes and pockmarks of exposed walls shall be filled with Portland cement grout and rubbed smooth. Concrete voids and honeycombs shall be chipped open with a light hammer to expose weak areas for inspection. At the direction of the Engineer, expansive repair grout shall be used for partial reconstruction of otherwise sound structures.*
- a. Walls:** Forms shall remain in place until the concrete reaches a minimum strength of 2000 p.s.i.
- b. Slabs:** Forms shall remain in place until the concrete reaches a minimum strength of 3000 p.s.i.
- 4. Manhole Riser Adjustments:** Manhole rings and covers shall be adjusted to match the slope and height, or grade, of pavements. In no case shall the surface pitch of the manhole ring and cover mismatch the pavement slope by more than ½ inch. The difference in height between the top of manhole cover and the top of precast cone shall not exceed 24 inches.
- f. Brick and Mortar Adjustments:** *Brick and mortar conforming to 2604.2.F, 2604.2.G, and 2604.2.D.4.C may be used in lieu of precast concrete adjustment rings. The bricks shall be saturated with water, surface dry, and clean. The joint space shall be completely filled and the excess mortar struck off.*
- g. In lieu of replacing concrete adjustment rings that are properly seated and structurally sound but have a small fracture, an external rubber chimney may be fitted to secure a watertight seal between the casting (manhole ring and cover) and the concrete cone barrel section.**
- B. Invert Channels:** Form concrete invert channels in manholes, inlets, and junction boxes to make changes in direction of flow with smooth curves of as large a radius as permitted by the inside dimension of the structure. Grade changes and transitions shall be smooth and uniform, and all parts of the invert channel and adjacent floor shall slope to drain. Channel bottom shall be finished smooth without roughness or irregularity. Invert channels for precast concrete structures may be cast integrally with the structure base slabs at the Contractor's option.
- C. Excavation:** All excavation shall be done in conformance with Section 2102 entitled "Grading."

Excavation for structures shall be carried a sufficient distance, but not less than 18 inches outside the limits of the structure, to permit efficient erection and removal of forms and laying of masonry units, and shall be sloped, stepped, or braced as required for stability. Unsuitable soils encountered at the bearing elevation of the structure shall be removed and replaced with either fill concrete or compacted granular material at the Contractor's option. Over excavation shall be corrected in like manner. The Contractor shall maintain the excavation free of standing water until backfilling is complete.

- D. Backfill of Structures:** All excavations of structures, such as cast-in-place and precast concrete structures for inlets, manholes, junction boxes, box culverts, and headwalls, shall be backfilled with suitable material placed and compacted in conformance with the specifications provided herein, and as otherwise provided in Section 2102 entitled "Grading."

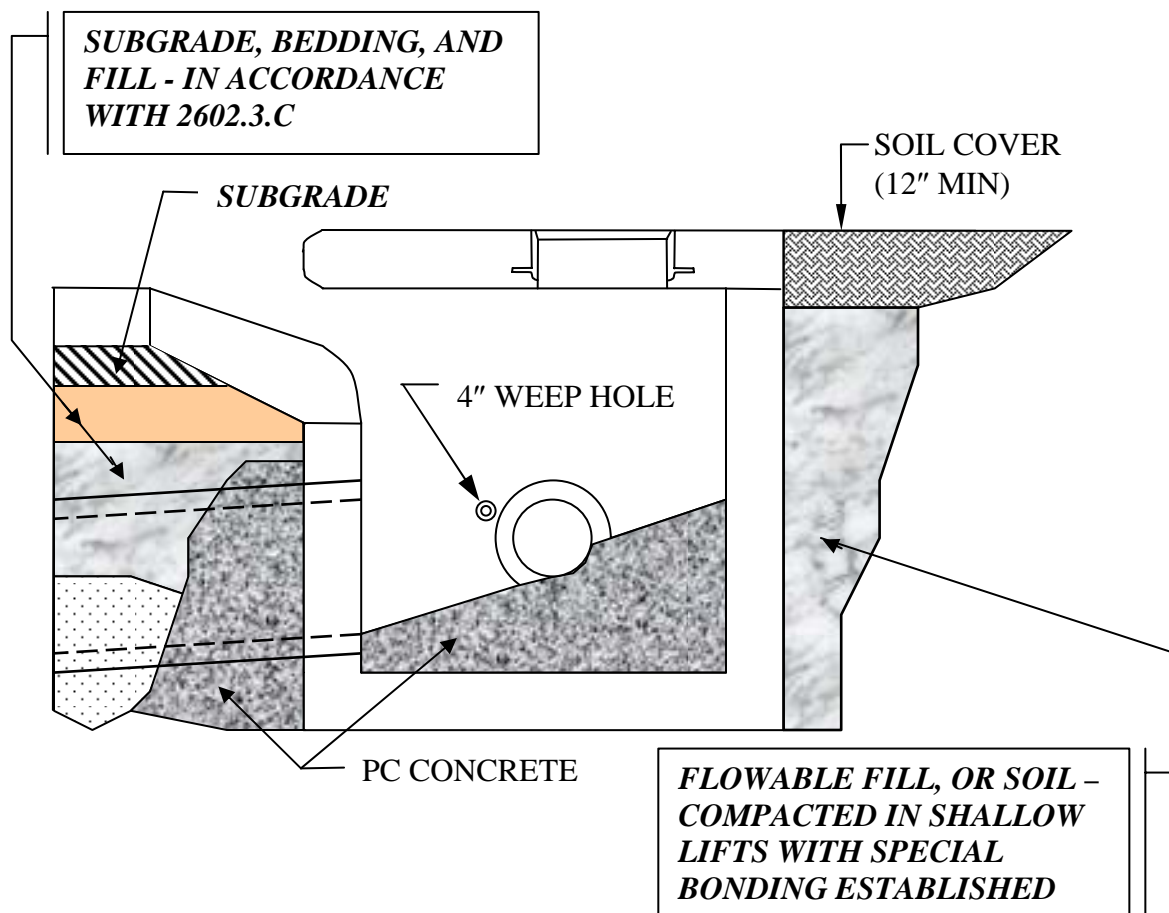

Note: Weep hole shall be backed by filter fabric or hardware cloth, and 3 cubic feet of granular material.

FIGURE 4
(Structures Adjacent to Street Pavements)

1. **Street Right-of-Way Areas:** *The trenched backfill areas around all storm sewer inlets, junction boxes, and manholes shall be backfilled with removable flowable-fill (CLSM) to a level flush with the bottom of pavement subgrade for paved areas or twelve-inches below finish grade for non-paved areas. When the Developer or Landowner chooses not to use CLSM as backfill material around structures adjacent to street pavement as shown in Figure 4 (above), the Developer must post an irrevocable Letter of Credit or a Maintenance Bond in accordance with Section 2602.3.C. Soil or untreated compacted aggregate backfill shall be compacted in four-inch lifts with hand-held mechanical (pneumatic or hydraulic) impact tampers. In non-paved areas, the top twelve inches shall be consolidated soil; the top six inches shall be topsoil.*

The external opening surfaces of weep holes shall be covered with hardware cloth and surrounded with a minimum of three cubic feet of consolidated granular bedding material. The configuration of materials properly placed shall be as shown in Figure 4.

2. **Areas other than Street Right-of-Way:** *The trenched backfill areas around all City-maintained storm sewer inlets, junction boxes, and manholes located within the pavements of private streets, driveways, and parking lots shall be backfilled as specified for the paved areas in Figure 4 and Section 2604.3.D.1 (above). City-maintained storm sewer structures that are located in non-paved areas shall be backfilled with removable CLSM, untreated compacted aggregate, consolidated granular bedding material, or compacted soil to a level twelve inches below finish grade. In non-paved areas, the top twelve inches shall be consolidated soil; the top six inches shall be topsoil.*
3. **Backfilling:** Backfilling shall conform to the requirements of Section 2602.3.C and as follows:
 - a. No backfill shall be placed over or around any structure until the concrete or mortar therein has attained a minimum strength of 2000 p.s.i. and can sufficiently support the loads imposed by the backfill without damage.
 - b. The Contractor shall use utmost care to avoid any wedging action between the side of the excavation and the structure that would cause any movement *or floating* of the structure. Any damage caused by premature backfill or by the use of equipment on or near a structure will be the responsibility of the Contractor.
 - c. Backfill shall be placed and compacted on all sides of the structure simultaneously, and operations shall be so conducted that the backfill is always at approximately the same elevation on all sides of the structure.
 - d. No excavated rock larger than 4 inches maximum dimension shall be placed within 1 foot of the exterior surface of any structure.

(THIS SPACE

IS INTENTIONALLY

LEFT BLANK)

SECTION 2605 OPEN CHANNELS

2605.1 Scope: This section includes all work for construction of open channel lining at the location, and to the lines, grades, and dimensions indicated on the Contract Drawings. Grading shall have been previously completed in accordance with Section 2100, "Grading and Site Preparation."

2605.1 Materials:

- A. Concrete:** Concrete shall be MCIB Mix Number A511-3/4-2. Reinforcing steel shall conform to ASTM A 615, Grade 60. Welded steel wire fabric shall conform to ASTM A 185.
- B. Stone:** Stone for riprap, grouted riprap, and gabion linings shall consist of quarried rock and be sound, durable, and angular in shape. No more than 10 percent shall have an elongation greater than 3:1, and no stone shall have an elongation greater than 4:1. Material shall be free from cracks, seams, or other defects. Shale and stone with shale seams are not acceptable.

1. The minimum unit weight of the stone shall be 155 pounds per cubic foot as computed by multiplying the specific gravity times 62.4 pounds per cubic foot.
2. Not more than 10 percent of the stone shall exhibit splitting, crumbling, or spalling when subject to 5 cycles of the sodium sulfate soundness test in accordance with ASTM C 88.
3. **Riprap and Grouted Riprap:** Stone shall be of the following gradations:

Riprap and grouted riprap shall have a minimum thickness of 15 inches, or 1.5 times as thick as the larger stones, whichever is greater. At least 60 percent of the mass shall be of pieces having a volume of one cubic foot or more and the pieces shall be well graded. No more than 6 percent of the stones shall weigh less than 10 pounds.

4. **Gabion Fill Stone:** Stone shall be of the following gradations:

<u>U.S. Standard Square Mesh Sieve</u>	<u>Percent Passing by Weight</u>
10"	100
8"	85 - 100
6"	0 - 15
4"	0 - 10
3"	0

Stone shall be graded within the above limits as required to provide a unit weight in-place of 100 pounds per cubic foot or greater.

- C. **Filter Blanket:** Filter blanket may be either of the following types at the Contractor's option.

1. **Granular Filter:** Granular filter material shall consist of sound durable rock particles conforming to the following gradation:

<u>Sieve Size</u>	<u>Cumulative Percent Passing By Weight</u>
1"	100
½"	70 - 100
No. 4	50 - 85
No. 10	35 - 70
No. 40	20 - 50
No. 100	15 - 40

2. **Filter Fabric:** Filter fabric shall consist of woven or nonwoven fabric. The synthetic fiber of either the woven or nonwoven fabric shall consist of polypropylene, nylon, or polyester filaments. The percent open area shall be not less than 4 percent nor more than 10 percent. The cloth shall provide an Equivalent Opening Size (EOS) no finer than the U.S. Standard Sieve No. 100. In addition, filter fabric shall meet the following physical requirements:
- a. **Tensile Strength:** Minimum grab tensile strength, both warpwise and fillingwise, shall be 200 pounds when tested in accordance with ASTM D 5034, using a 4-inch by 6-inch specimen and a jaw speed of 12 inches per minute.
 - b. **Elongation:** Grab elongation shall be not less than 15 percent nor more than 60 percent, both warpwise and fillingwise, when tested in accordance with ASTM D 5034.
 - c. **Tear Strength:** Minimum trapezoid tear strength shall be 100 pounds, both warpwise and fillingwise. Method of test for woven fabrics shall be in accordance with ASTM D 4533.
 - d. **Bursting Strength:** Minimum bursting strength shall be 400 psi when tested in accordance with ASTM D 3887.
 - e. **Seam Strength:** Woven fabric shall have a minimum seam-breaking strength of 180 pounds when tested in accordance with ASTM D 1683, using a jaw speed of 12 inches per minute.
 - f. **Width:** Filter fabric shall be furnished in widths of not less than 6 feet.

D. Gabion Baskets: Baskets shall be of the dimensions indicated on the drawings and be fabricated using hexagonal triple-twist wire mesh.

1. **Wire:** Wire shall be galvanized steel having a minimum tensile strength of 60,000 psi, and shall be zinc coated in accordance with ASTM A 641 Class 3.
2. **Wire Mesh:** Maximum dimension of the mesh opening shall be 4-1/2 inches or less, and the maximum area of the mesh opening shall not exceed 12 square inches. Wire shall be 0.120-inch (minimum) diameter.
3. **Selvage Wire:** Selvage wire shall be 0.1535-inch (minimum) diameter. All perimeter edges so the joints formed by typing the selvages have a strength equal to or greater than the body of the basket.
4. **Lacing and Stay Wire:** Wire shall be 0.0866-inch diameter or larger. Other connections methods, such as stainless steel clips, may be substituted with approval of the Engineer.
5. **Diaphragms:** Gabions shall be divided into cells not greater than 4 feet in width by wire mesh diaphragms. Diaphragms shall be factory secured to the base of the basket by continuous spiral wire.
6. **PVC (Polyvinyl Chloride) Coating:** Where in the Contract Drawings, all wire used in the fabrication of the baskets and in the wiring operations during construction shall, after zinc coating, have an extruded coating of PVC. The coating shall be gray in color ranging between series 26187 and 26293 or between series 26373 and 26375, semigloss, as per Federal Standard 595B. The PVC coating shall be a nominal thickness of 0.02165 inches and shall nowhere be less than 0.015 inches in thickness. The coating shall be resistant to the destructive effects of immersion in acidic, salt or polluted water, exposure to ultraviolet light, and abrasion and shall retain these characteristics after a period of not less than 3,000 hours under test in accordance with ASTM G-23.

E. Grout: Grout for grouted riprap shall be a sand/cement mixture containing 420 pounds of cement per cubic yard with 6 percent air entrainment. It shall have a consistency thin enough to permit thorough penetration of the grout into the joints and voids between the stones.

F. Sod: Sod shall conform to the requirements of *Section 2405.1*.

- G. Seed:** Seeding shall conform to the requirements of Section **2404.2. Mix #1** seed shall be used.

2605.3 Construction Details:

A. Foundation Preparation: After completion of grading in accordance with Section 2100, the area to receive channel lining shall be trimmed and dressed to conform to the cross sections indicated on the drawings within a tolerance of plus or minus 1 inch from the theoretical slope lines and grades. All deleterious materials shall be removed from the foundation area.

B. Concrete Lining:

- 1. Preparation:** Subgrade shall be moistened by sprinkling. Forms shall be securely staked, braced, and set to line and grade. Reinforcement and tie bars shall be held in position by bar chairs, concrete brick, or other approved devices.
- 2. Placing and Finishing:** Place, consolidate, and strike off concrete to the thickness indicated on the drawings. concrete shall be tamped or vibrated to eliminate all voids and bring sufficient mortar to the top for finishing. Surface finish shall be a wood-float finish. Round all edges and joints with a 1/4 inch radius edging tool, except contraction joints may be sawed to a depth of 30 percent of the thickness of the concrete lining after concrete has hardened but before uncontrolled cracking occurs. Apply curing membrane as specified in Section 2208.2.F.

C. Filter Blanket:

- 1. Granular Filter:** Place granular filter to its full thickness in a single operation. Construction methods shall be such that the materials is placed without segregation. Compaction of granular filter material is not required.
- 2. Filter Fabric:** Place filter fabric with its long dimension horizontal and lay free of tension, stress, folds, wrinkles, or creases.
 - a.** Place to provide 18 inches minimum overlap at each joint and anchor to prevent dislocation during construction of overlaying material.
 - b.** Fabric shall not be left exposed more than two weeks prior to placement of overlaying material. Tracked or wheeled equipment or vehicles shall not be operated on the fabric.

D. Riprap Placement: Riprap shall be placed on the prepared foundation in a manner which will provide a reasonably well-graded mass of stone with the minimum practicable percentage of voids. The entire mass of stone shall be placed so as to be in conformance with the lines, grades, and thickness indicated. A filter blanket of filter fabric conforming to Section 2605.2 C.2. shall be constructed under all riprap, grouted or ungrouted. Riprap shall be placed to full-course thickness in one operation and in such a manner as to avoid displacing the fabric. The Contractor shall place the riprap in such a way as to not tear, puncture, or shift the fabric. Riprap shall not be dropped more than 3 feet when being placed directly on the fabric. Tears or rips in the fabric shall be repaired with fabric lapped a minimum of 12 inches in all directions.

1. **Placing:** Placing of riprap in layers, or by dumping into chutes, or by similar methods likely to cause segregation will not be permitted.
2. **Distributing:** The larger stones shall be well distributed and the entire mass of stone shall conform to the specified gradation. All materials shall be so placed and distributed that there will be no objectionable accumulations of either the larger or smaller sizes of stone.
3. **Hand Placing:** It is the intent of these specifications to produce a fairly compact riprap protection in which all sizes of material are placed in their proper proportions. Hand placing or rearranging of individual stones by mechanical equipment may be required to the extent necessary to secure the specified results.

E. Grouted Riprap: Riprap shall be placed in conformance with Section 2605.3.D (Riprap Placement). Grout shall be placed in such a manner to produce a securely bound solid mass with the voids completely filled.

After the voids have been completely filled, the surface shall be swept clean with a stiff bristle broom and water to expose the stone surface and natural color of the stone. Most stones should protrude 1 to 3 inches above the grout unless otherwise specified on the Contract Drawings.

The grout shall be cured by any of the methods specified for concrete sidewalks and driveways in Section 2301.5.C, except that transparent membrane shall be used in lieu of white pigmented membrane.

During cold weather, the limitations and protection requirements of concrete as specified in the most current MCIB Standard Concrete Specifications shall apply to the grouting.

A toewall shall be constructed at the upstream and downstream ends of all grouted riprap unless another permanent lining materials is constructed to continue the channel. The toewall shall be constructed across the entire section and shall be a minimum of 18 inches deep below the bottom of the grouted riprap and 12 inches wide. The toewall material shall be grouted riprap.

F. Gabion Lining:

- 1. Assembly:** Assemble each gabion unit by binding all vertical edges together with a continuous piece of connecting wire stitched around the vertical edge with coils spaced at 3 inches or less. Set empty units to line and grade and joining units by stitching with connecting wire along adjoining edges. Install and securely fasten internal tie wires in each cell if necessary to retain the shape of the cell during filling operations.
- 2. Filling:** Fill gabion cells with stone carefully by hand or machine to provide a minimum of voids and avoid bulges and distortions of the gabion. After filling, secure the lid to the sides, ends, and diaphragm by stitching with connecting wire.
- 3. Filter Fabric/Gabion Unit Placement:** A filter blanket of filter fabric conforming to Section 2605.2.C.2 shall be constructed under all Gabion Linings. The Contractor shall place the gabions in such a way as to avoid tearing, puncturing, or shifting the fabric. Tears or rips in the fabric shall be repaired with fabric lapped a minimum of 12 inches in all directions.

G. Sod: Sod shall be *installed* as specified in Section **2406**, except all sod placed in drainage channels or ditches, including both the side slopes and bottom, shall be anchored as specified in Section **2406.4.D.4**, Anchoring Sod.

SECTION 2606 MEASUREMENT AND PAYMENT

2606.1 Measurement: The quantities of accepted work will be measured in the following units. All measurements will be plan measure except for authorized changes.

A. Pipe: By the lineal foot of each size and type. Measurement will be to the nearest 0.1 foot for each line between structures, and made to the inside face of the connecting structure. Precast or prefabricated end sections will be excluded from the pipe measurement.

- B. Prefabricated or Precast End Sections:** By the number of each size and type.
- C. Concrete Box Culverts:** By the lineal foot of each size and type. Measurement will be along the centerline of the culvert between the back faces of the headwalls. Headwalls will be measured separately as “Structures.”
- D. Structures:** Inlets, manholes, headwalls, endwalls, *curb inlets, field inlets*, and other similar structures will be measured by their number of each size and type, *as* listed in the *Contract Documents*.
- E. Casings:** Casings for pipe installation by boring and/or jacking methods will be measured by the lineal foot of each size and type.
- F. Pipe Encasement:** Pipe encasement will be measured by the lineal foot of each size and type.
- G. Concrete Channel Lining:** By the square yards of surface area. Measurement will be parallel to sloping surfaces.
- H. Filter Blanket:** *Unless otherwise stated in the Agreement, there will be no separate measurement or payment for filter blanket. All costs for such work shall be included in the price of the related item.*
- I. Riprap:** *By the square yards of surface area. Measurement will be parallel to sloping surfaces. The thickness of the riprap shall conform to the plan dimension. Measurement and payment of the filter fabric shall be included in the cost per square yard of the riprap.*
- J. Grouted Riprap:** By the square yards of surface area. Measurement will be parallel to sloping surfaces. The thickness for grouted riprap shall be measured from the top of the grout line to the bottom of the riprap and shall conform to the plan dimension. Measurement and payment of the filter fabric shall be included in the cost per square yard of the grouted riprap.
- K. Gabion Baskets:** By the cubic yard on the basis of plan dimensions.
- L. Sodding:** Measurement shall be by the lineal foot of pipe over which sod is placed or by the lineal foot of sodded ditch unless otherwise specified. For lined (riprap, grouted riprap, or concrete) channels, sod placement and/or repairs shall be incidental to the cost of placement of the lining material.

M. Seeding: Measurement shall be by the lineal foot of pipe over which seed is placed or by the lineal foot of seeded ditch unless otherwise specified. For lined (riprap, grouted riprap, or concrete) channels, seed placement and/or repairs shall be incidental to the cost of placement of the lining material.

2606.2 Payment: Payment will be made at the respective unit of lump sum price listed in the Agreement, and shall be full compensation for all labor, materials, and equipment necessary to complete the respective unit in place. There will be no separate measurement or payment for any item of work not specifically identified and listed in the Agreement, and all such work shall be considered a subsidiary item with all costs pertaining thereto included in the prices for other items listed in the Agreement. At the Engineer's option, partial payment may be made for any item listed in the Agreement, providing that the Contractor is diligently and satisfactorily pursuing full completion of such partially complete item in accordance with the approved job progress schedule.