

**DIVISION II  
CONSTRUCTION AND MATERIAL SPECIFICATIONS  
SEWERS**

**SECTION 2500 SANITARY SEWERS**

Approved and adopted this 16<sup>th</sup> day of December, 1992

**Kansas City Metropolitan Chapter  
of the American Public Works Association**

<b>Section</b>	<b>Title</b>	<b>Page No.</b>
<b>2500</b>	<b><i>Index</i></b>	<b><i>i</i></b>
<b>2500</b>	<b><i>List of Effective Pages</i></b>	<b><i>iii</i></b>
<b>2500</b>	<b><i>Resolution</i></b>	<b><i>iv</i></b>
<b>2501</b>	<b>GENERAL.....</b>	<b>1</b>
2502.1	Description.....	1
2502.2	Specification Modifications .....	1
2502.3	Revisions of Standards.....	1
<b>2503</b>	<b>MATERIALS .....</b>	<b>1</b>
2503.1	General .. .....	1
2503.2	Pipe, Fittings, Joints, Coatings and Linings .....	2
2503.3	Pipe, Embedment, and Encasement Materials.....	6
2503.4	Backfill Materials .....	6
2503.5	Tunneling, Boring and Jacking Materials .....	6.1
<b>2504</b>	<b>SITE PREPARATION .....</b>	<b>8</b>
2504.1	Scope.....	8
2504.2	Materials.....	8
2504.3	Obstructions .....	8
<b>2505</b>	<b>EXCAVATION .....</b>	<b>11</b>
2505.1	Scope.....	11
2505.2	General .....	12
2505.3	Unclassified Excavation .....	12
2505.4	Rock Excavation .....	12
2505.5	Earth Excavation .....	12
2505.6	De-Watering .....	12
2505.7	Blasting .....	12
2505.8	No-Blasting Areas .....	12
2505.9	Open-Cut Method (Tracking) .....	12
2505.10	Tunneling, Boring, and Jacking .....	16
<b>2506</b>	<b>INSTALLATION .....</b>	<b>17</b>
2506.1	Scope.....	17
2506.2	General .....	17

<b>Section</b>	<b>Title</b>	<b>Page No.</b>
2506.3	Detailed Installation Requirements.....	22
2506.4	Casing and Carrier Conduits .....	22.1
<b>2507</b>	<b>BACKFILL</b> .....	<b>24</b>
2507.1	Scope.....	24
2507.2	General .....	24
2507.3	Backfilling in Street or Alley Right-of-Way .....	25
2507.4	Backfilling in Areas Other Than Street or Alley Right-of-Way .....	25
2507.5	Backfill Around Structures .....	25
<b>2508</b>	<b>RESTORATION</b> .....	<b>26</b>
2508.1	Scope.....	26
2508.2	General .....	26
2508.3	Clean-Up .....	26
2508.4	Finish Grading .....	26
2508.5	Seeding .....	26
2508.6	Sodding .....	26
2508.7	Pavement Replacement .....	26
2508.8	Fences .....	27
2508.9	Walls .....	27
2508.10	Trees, Shrubs and Bushes .....	27
<b>2509</b>	<b>TESTING</b> .....	<b>27</b>
2509.1	Scope.....	27
2509.2	General .....	27
2509.3	Alignment and Grade .....	28
2509.4	Infiltration – Exfiltration .....	28
2509.5	Earth Excavation .....	32
2509.6	Soil Density Tests .....	33
<b>2510</b>	<b>MANHOLES AND SPECIAL STRUCTURES</b> .....	<b>33</b>
2510.1	Scope.....	33
2510.2	General .....	33
2510.3	Manhole Materials .....	34
2510.4	Manhole Site Preparation .....	37.1
2510.5	Manhole Excavation .....	37.1
2510.6	Manhole Installation.....	38
2510.7	Manhole Backfilling .....	40.1
2510.8	Restoration .....	40.1
2510.9	Manhole Testing .....	41
<b>2511</b>	<b>MEASUREMENT AND PAYMENT</b> .....	<b>41.1</b>
2511.1	Measurement.....	41.1
2511.2	Payment.....	42

## SECTION 2500 SANITARY SEWERS

### LIST OF EFFECTIVE PAGES

<b>Page</b>	<b>Date</b>	<b>Page</b>	<b>Date</b>	<b>Page</b>	<b>Date</b>
i	1/4/04	16	Original	30	Original
ii	1/4/04	17	Original	31	Original
iii	1/1/04	18	7/1/98	32	7/1/98
iv	1/1/04	19	Original	33	Original
1	Original	20	Original	34	1/1/04
2	Original	21	10/1/04	35	1/1/04
3	10/1/04	22	1/1/04	36	10/1/05
4	1/1/04	22.1	1/1/04	36.1	10/1/05
5	1/1/04	23	1/1/04	37	1/1/04
6	7/1/98	24	1/1/04	37.1	10/1/05
6.1	7/1/98	25	Original	37.2	10/1/05
7	1/1/04	26	Original	38	1/1/04
8	Original	27	Original	39	1/1/04
9	Original	28	Original	39.1	1/1/04
10	Original	29	Original	40	1/1/04
11	Original			40.1	1/1/04
12	1/1/04			41	7/1/98
13	Original			41.1	1/1/04
14	Original			42	Original
15	Original				

## RESOLUTION

Be it resolved by the Director of Public Works of Kansas City, Missouri that the following listed Section of Division II, Construction and Materials Specifications, approved and adopted December 16<sup>th</sup>, 1992 by the Kansas City Metropolitan Chapter of the American Public Works Association is approved and adopted as Official Standard Construction and Materials Specifications for the Department of Public Works of Kansas City, Missouri with like section and page numbers, except as modified by the replacement pages of the July 1<sup>st</sup>, 1998, KCMO Supplement and hereby further modified by the replacement pages of the attached supplement.

Section 2500 Construction and Material Specifications for Sanitary Sewers

A copy of said specifications criteria and supplement are attached hereto and incorporated herein by reference.

The criteria shall become effective May 1, 2009 and shall supersede, in whole page format, all previously adopted Standard Specifications having the same section and page numbers as this supplement replaces. The previously adopted KCMO Supplement pages that are not replaced by the attached specifications criteria and supplement shall remain in effect.

Approved and adopted as Official Document No CS090007 this second day of July, 2008.



Stan Harris, P.E.  
Director of Public Works  
of Kansas City, Missouri

- c. Joints: Pipe joints and fittings shall be solvent-cement or elastomeric conforming to ASTM D 2680. Gaskets for elastomeric joints shall conform to ASTM F 477. Joint tightness shall also conform to ASTM D 3212. Natural rubber gaskets will not be accepted.
  - d. Fittings: Fittings defined suitable for assembly to four (4) inches or six (6) inch building service lines shall be bell-end with a minimum wall thickness conforming to SDR 23.5 and shall be provided by the pipe manufacturer.
4. Ductile-Iron Pipe and Fittings: Pipe and fittings shall conform to ANSI A21.51, except as otherwise specified herein.
- a. General: Furnish maximum pipe lengths normally produced by the manufacturer except for fittings, closures and specials.
  - b. ***Design: All ductile iron pipe shall be Class 52 meeting the requirements of AWWA C150 (ANSI A21.50) and AWWA C151 (ANSI A21.51) or as shown on the drawings.***
  - c. Joints: Mechanical and push-on joints for pipe and fittings shall conform to the requirements of ANSI A21.11. Flanged joints for ductile iron pipe and fittings shall conform to the requirements of A21.10. Gaskets shall be neoprene or other synthetic rubber material. Natural rubber gaskets will not be acceptable.
  - d. Fittings: Fittings shall be in accordance with ANSI/AWWA C110 and shall have a pressure rating of not less than that specified for the pipe. Fittings used with ductile iron pipe shall be ductile iron or cast iron. Fittings for pipe with mechanical joints shall have mechanical joints. Fittings for pipe with push-on joints shall have either mechanical joints or push-on joints.
  - e. Coatings: Pipe and fittings shall be furnished with exterior bituminous coating conforming to ANSI A 21.51.
  - f. Linings: Pipe and fitting linings shall conform to the following:
    - (1) ***Pipe shall have an interior Calcium Aluminate-mortar lining conforming to AWWA C104 (ANSI A 21.4), a 40 mil. Polyethylene lining in accordance with ASTM D 1248 or be PVC (polyvinyl chloride) lined.***
    - (2) Pipe and fittings shall have an interior coating not less than one (1) mil in thickness which conforms to all appropriate requirements for seal coat in ANSI/A 21.4

- g. Polyethylene Encasement: Pipe and fittings shall be installed with a polyethylene tube encasement having a thickness of 0.008" (8 mils) and conforming to ASTM D-1248, Type 1, Class C, Grade E-1 material.

3

- 5. Polyvinyl Chloride (PVC) Pressure Rated Plastic Pipe (SDR) and Fittings: Pipe and fittings shall conform to ASTM D 2241, except as otherwise specified herein.
  - a. General: Furnish maximum pipe lengths normally produced by the manufacturer, except for fittings, closures and specials. Pipe shall be used only for pressure flow systems.
  - b. Materials: The pipe shall be made of PVC plastic pipe having a cell classification of 12454 B or 12454 C as defined in ASTM D 1784.
  - c. Design: Pressure flow systems, i.e., force mains, shall have the wall thickness shown on the plans, with a minimum wall thickness not less than SDR 32.5 with a minimum burst pressure not less than 400 psi conforming to pipe materials designation codes PVC 1120, PVC 1220, or PVC 2120.
  - d. Joints: Pressure flow systems shall be joined in accordance with ASTM D 3139 with particular attention given to Section 5.3.
  - e. Fittings: fittings for pressure flow systems shall have a minimum wall thickness conforming to SDR 32.5 and a minimum hydrostatic design stress of 400 psi conforming to pipe materials designation codes PVC 1120, PVC 1220, and PVC 2120.
- 6. ***Type PSM polyvinyl chloride (PVC) Sewer Pipe and Fittings: 4 through 15 inch diameter pipe and fittings shall conform to ASTM D 3034 and pipe having diameter eighteen (18) through twenty seven (27) inch shall conform to ASTM F 679 except as otherwise specified herein.***
  - a. General: Furnish maximum pipe lengths normally produced by the manufacturer except for fittings, closures and specials.
  - b. Materials: The pipe shall be made of PVC plastic having a cell classification of 12454 B or 12454 C or 13364 B as defined in ASTM D 1784.
  - c. ***Design: Pipe shall have an integral bell and spigot joint. Wall thickness shall conform to SDR 26 for ASTM D 3034 pipe. Wall thickness shall conform to SDR21 for ASTM D 2241 pipe. Wall thickness shall conform to T-1 for ASTM F 679 pipe. The maximum cover depth for SDR 26 pipe shall be twenty two (22) feet and the maximum cover depth for SDR 21 pipe shall be thirty (30) feet. If for any reason, the maximum cover depth is exceeded, the contractor shall suspend pipe installation and notify the design engineer and the City.***

- d. Joints: Joint tightness shall conform to ASTM D 3212. Joints shall be push-on type only with the bell-end grooved to receive a gasket. Elastomeric seal (gasket) shall have a basic polymer of synthetic rubber conforming to ASTM F477. Natural rubber gaskets will not be used.

4

- e. ***Fittings: Fittings defined as wye (Y) connections suitable for assembly to four (4) inch or six (6) inch building service lines shall be bell-end with a minimum wall thickness conforming to SDR 26 and shall be furnished by the pipe manufacturer. A special design is required for service connections 8 inches and larger. Saddle connections will not be permitted during sewer main installation.***

- 7. Reinforced Concrete Pipe and Fittings: Pipe and fittings shall conform to ASTM C 76 except as otherwise specified herein.
  - a. General: Furnish maximum lengths normally produced by the manufacturer except for fittings, closures and specials.
  - b. Design: Pipe shall be Class III, Class IV or Class V, wall B as shown on plans. Fine aggregate shall be natural sand conforming to the requirements on MCIB Section 3-1, Concrete Materials. Reinforcement may be circular or elliptical. Elliptically reinforced pipe shall be marked in accordance with Section 17.2, ASTM C 76 for correct installation. Modified or special designs are prohibited unless so specified in the Special Provisions.
  - c. Joints: Pipe and fittings shall be furnished with either spigot groove type joint with O-ring gasket or steel end joint with spigot groove and O-ring gasket conforming to ASTM C 361 and ASTM C 443. The basic polymer for O-ring gaskets shall be synthetic rubber and shall conform to ASTM C 361 or ASTM C 443.
  - d. Fittings and Specials: Provide strength equal to design D-loads of adjacent pipe and be fabricated as one of the following types:
    - (1) Steel cylinder segments not less than U.S. No. 16 gauge lined with three-fourths (3/4) inch concrete or mortar and reinforced concrete exterior.
    - (2) Concrete pipe sections shall be cut while still green; reinforcing exposed and welded together at junctions and miters. Splice shall be built up to nominal wall thickness with mortar or concrete. Miters shall not exceed 30 degrees at deflection angles between segments. Minimum centerline curve radius shall not be less than twice the pipe diameter.
- 8. Vitrified Clay Pipe and Fittings: Pipe and fittings shall conform to ASTM C 700 Extra Strength except as otherwise specified herein.

- a. General: Furnish maximum pipe lengths normally produced by the manufacturer with either bell-end or plain-end except for fittings, closures and specials.
- b. Joints: All pipe shall conform to ASTM C 425 with synthetic rubber seals. All compression couplings for clay plain-end pipe shall conform to ASTM C 594.

2503.3 Pipe Embedment Materials.

1. Scope: Pipe embedment materials shall be furnished and installed to complete the work shown on the Plans or as called for in the Contract Documents.
2. **Granular Bedding Material:** Granular bedding material shall be crushed *clean limestone aggregate meeting one of the following gradations:*

*Bedding Material Gradation Limits, % Passing*

<i>Sieve Size</i>	<i>3/4"</i>	<i>1/2"</i>	<i>3/8"</i>
<i>1"</i>	<i>100</i>		
<i>3/4"</i>	<i>90-100</i>	<i>100</i>	
<i>1/2"</i>		<i>80-100</i>	
<i>3/8"</i>	<i>20-55</i>	<i>40-70</i>	<i>100</i>
<i>No. 4</i>	<i>0-10</i>	<i>0-15</i>	<i>30-40</i>
<i>No. 8</i>	<i>0-5</i>	<i>0-5</i>	<i>0-4</i>

*In areas where the pipe trench is below the potential high point of the water table, only three-eighths (3/8") inch bedding may be used.*

3. Concrete for embedment and encasement:
  - a. Concrete shall test not less than a twenty-eight (28) day compressive strength of 3000 psi and shall otherwise conform to Section 2510.3.6.
  - b. Reinforcing steel when required shall be placed as shown on the Plans and shall conform to Section 2510.3.7.

2503.4 Backfill Materials:

1. *Scope: Backfill materials shall be required and/or permitted to complete the work shown on the plans or called for in the contract documents.*
2. *Granular Backfill Material: Granular backfill material shall meet the gradation requirements as outlined in Section 2202.2.*
3. *Select Earth Backfill Material: Select earth backfill shall be finely divided job excavated material free from debris, organic matter, rocks larger than one (1) inch and/or frozen materials.*
4. *Other Earth Backfill: Other backfill may be job excavated material free from debris and organic matter. No rock greater than one foot in its longest axis shall be placed in any trench excavation as backfill.*
5. *All backfill under street or alley pavement shall be controlled low strength material meeting the requirements of 2602.2 unless otherwise approved by the Engineer.*

2503.5 Tunneling, Boring and Jacking Materials:

1. Scope: This section governs the furnishing of all materials necessary for the construction of tunnels at locations shown on the Plans or where constructed at the Contractor's option when approved by the Engineer.
2. General: Furnish materials and necessary accessories with strengths, thicknesses, coatings, and fitting indicated, specified and/or necessary to complete the work.

3. **Steel Liner Plate:** Steel tunnel liner plates shall be Armco “Standard,” Commercial Shearing and Stamping Company “Commercial,” Republic “Truscon Paneled Out,” or equal and shall be galvanized in accordance with ASTM A 123. The design and shape of the liner plates shall be such that assembly can take place entirely from within the tunnel liner. Liner plates shall be capable of withstanding the ring thrust load and transmitting this from plate to plate. The minimum outside diameter shall be four (4) feet and the minimum wall thickness shall be United States Standard Gauge 12 (0.2046 inches). Sufficient sections shall be provided with one and one-half (1 ½) inch or larger grouting holes located near the centers so that when the plates are installed there will be one line of holes on either side of the tunnel and one at the crown: the lower line of holes on each side shall not be more than eighteen (18) inches above the invert. The holes in each line shall not be more than five (5) feet apart and unless otherwise approved, shall be staggered. Bolts and nuts shall conform to ASTM A 153, A 307, A 325 and A 449 as applicable. Steel liner plates shall have bolted joints in both longitudinal joints in adjacent rings when assembling.
4. **Steel Casings:** Steel casings for bored or jacked construction shall be steel pipe conforming to ASTM A 139 with a minimum diameter as shown on the Plans. Corrugated steel casing pipe will be considered on a case-by-case basis.

a. Minimum wall thickness shall be in accordance with the following table:

Diameter of Casing-Inches	Nominal Wall Thickness-Inches	
	Under Railroads	All Other Uses
16	0.312	0.188
18	0.312	0.250
20	0.375	0.250
22	0.375	0.250
24	0.406	0.281
26	0.438	0.281
28	0.469	0.312
30	0.469	0.312
32	0.500	0.312
34	0.500	0.312
36	0.500	0.344

- b. Steel shall be Grade B under railroads and Grade A on all other uses.
- c. Steel pipe shall have welded joints in accordance with AWWA C 206
5. **Reinforced Concrete Pipe:** Reinforced concrete pipe used as casing shall conform to ASTM C 76 except as otherwise specified under Section 2503.2.7.

2505.3 Unclassified Excavation: Unclassified excavation is defined as the removal of all material encountered regardless of its nature. All material excavated will be considered as unclassified Excavation unless the Special Provisions specify Classified Materials.

2505.4 Rock Excavation: Rock excavation is defined as the removal of all rock ledges 6 inches or more in thickness, detached rock or boulders having a volume of more than 1 ½ cubic yards and shale occurring in its natural state, hard and unweathered. A rock ledge is defined as a continuous body of rock that may include interbedded seams of soft materials. Such interbedded soft material less than 12 inches in thickness will be included in the measurement of rock excavation. Such seams 12 inches or greater in thickness will be included only in the measurement of earth excavation.

2505.5 Earth Excavation: Earth excavation is defined as the removal of all material not defined as rock.

2505.6 De-Watering: The Contractor shall remove any water that may accumulate or be found in the trenches and other excavations made under the Contract.

The Contractor shall form all dams, flumes or other works necessary to keep the excavation clear of water while the sewers and their foundations, and other foundation works, are being constructed. All water shall be removed from such excavation in a manner that will not damage property.

2505.7 Blasting: When blasting is permitted by the Engineer, the Contractor shall use the utmost care to protect life and property. The Contractor shall comply with all laws, ordinances, and the applicable safety code requirements and regulations relative to the handling, storage and use of explosives and protection of life and property, and he shall be responsible for all damage thereto caused by his or his subcontractor's operations.

***The Contractor shall provide insurance as required by Section 00700 Construction General Conditions, 00800 Construction Supplementary Conditions and the Special Provisions. The governing agency shall be notified at least twenty four (24) hours before blasting operations begin.***

2505.8 No Blasting Areas: No blasting will be allowed in "No Blasting Areas" shown on the Plans.

2505.9 Open-Cut Method (Trenching):

1. Scope: This item establishes the requirements to be followed for pipeline excavation performed by the open-cut method (trenching).
2. General: Excavations for pipelines shall be accomplished by the open-cut method (trenching) except as specified or approved by the Engineer. Trenching shall be a minimum inconvenience and disturbance to the general public.

furnish and installed as necessary to preserve and maintain exposed excavation faces, to protect existing improvements, to protect the proposed pipeline and to provide for safety.

Shoring or other methods for support of trench walls is the responsibility of the Contractor and shall be accomplished by methods that will not adversely affect pipeline alignment, grade and/or structural integrity.

All bracing, sheeting and/or shoring installed below a horizontal plane six (6) inches above top of proposed pipe shall not be disturbed or removed after pipe and/or pipe embedment has been installed unless otherwise specified. The bottom skids of a trench shield shall not extend lower than six (6) inches above top of proposed pipe.

5. ***Pipe Embedment : All pipe embedment shall conform to Class B, First Class Modified, unless otherwise specified. Installation shall be in strict conformance with instructions for the appropriate Class being utilized.***

All Class A concrete embedment for rigid conduits shall begin and end at a pipe joint.

6. Bedding Installation:
- a. The trench subgrade shall be prepared to provide a uniform and continuous pipe support between pipe bells and joints.
  - b. Place and consolidate embedment material by shovel slicing or vibrating and prepare embedment material so that the pipe will be true to line and grade after installation.
  - c. After each pipe has been brought to grade, aligned, and placed in final position, deposit and consolidate by shovel slicing sufficient bedding material under the pipe haunches and on each side of the pipe to hold the pipe in proper position during subsequent pipe jointing, bedding, and backfilling operations. Place bedding material uniformly and simultaneously on each side of the pipe to prevent lateral displacement.
  - d. Place pipe that is to be bedded in Class A (concrete) embedment in proper position on temporary supports consisting of wood blocks or bricks with wood wedges. When necessary, anchor or weight the pipe to prevent flotation when the concrete is placed.
  - e. Place concrete for Class A (concrete) embedment or encasement uniformly on each side of the pipe and deposit at approximately its final position. Do not move concrete more than five (5) feet from its point of placement.
  - f. If unstable subgrade conditions are encountered and it is determined by the Engineer that the bedding specified will not provide suitable support for the

Contract Documents: All damage caused by the Contractor's failure to provide adequate thrust supports shall be corrected by the Contractor at no additional cost to the Owner.

11. Anchors: Pipelines shall be anchored in accordance with the table below:

PIPELINE ANCHORS

<u>Percent Of Grade</u>	<u>Center to Center Max. Spacing (Feet)</u>
20-35	36
35-50	24
50	16

The anchor shall be concrete or other material approved by the Engineer. Concrete anchors shall have a minimum thickness of twelve (12) inches. The anchor shall extend not less than one (1) foot into undisturbed earth on the sides and bottom and one (1) foot above top of pipe. In incompressible material, the above dimensions may be six (6) inches each side and bottom. The anchor shall support a joint fitting.

12. Pipe Laying: All pipe shall be installed in accordance with the pipe manufacturer's recommendations, except as modified herein.
- a. Pipe laying shall not proceed if the trench width as measured at the top of pipe exceeds the maximum allowable trench width. If this occurs, the Contractor shall submit to the Engineer for approval a better bedding for the pipe or pipe of sufficient strength to provide safe supporting strength.
  - b. All pipe and fittings shall be stored and handled with care to prevent damage thereto. Do not use hooks to transport or handle pipe or fittings. Do not drop pipe or fittings.
  - c. Rejected pipe and fittings shall be marked and removed from the Project Site at no cost to the Owner. All pipe and fittings shall be examined for soundness and specification compliance prior to placement in the trench, and rejected pipe or fittings shall not be incorporated into the pipeline. Check the class or pipe strength to be sure proper pipe is installed.
  - d. Clean joint contact surfaces prior to jointing. Use lubricants, primers or adhesives as recommended by the pipe or joint manufacturer.
  - e. ***Pipe installation shall begin at the lowest point and proceed uninterrupted upgrade without gaps unless otherwise approved, in writing, by the Engineer.***

- f. Unless otherwise required, lay all pipe straight between manholes. Excavate bell holes for each pipe joint. When jointed, the pipe shall form a true and smooth pipeline.
  - g. Pipe connecting to a structure shall be supported with Class A embedment, cradle or encasement to the first joint outside the structure excavation. If flexible wall connections are used, Class B embedment may be used in lieu of concrete embedment provided the height of backfill does not exceed the cover depths in Sections 2503.2.6.c and 2505.9.6.
  - h. All pipelines shall be plugged at the end of each day's work. Plugs or other positive methods of sealing shall be used at all times to protect any existing system from entrance of storm water or other foreign matter.
  - i. When a sanitary sewer line crosses an existing pipeline and the clearance is less than two (2) feet, special embedment may be required.
13. Connection of Pipes of Dissimilar Materials: The connection of pipes of different materials shall be made using approved transition coupling and shall provide a permanent and watertight connection that will withstand the hydrostatic test pressure.

2506.3 Detailed Installation Requirements: All pipes shall be installed in accordance with the following standards:

- 1. ASTM D-2321 – ABS Solid Wall, ABS Composite Wall, ASTM D-2321 – PVC Solid Wall, PVC Composite Wall.
- 2. ***ANSI/AWWA C 600- Ductile Iron Pipe and the following requirements for polyethylene tube protection:***
- 3. ASTM C 12 – Vitrified Clay Pipe.
- 4. Reinforced Concrete Pipe – Installed in accordance with American Concrete Pipe Association's "Installation Manual".
- 5. ***Polyethylene tube protection shall be installed in accordance with ANSI/AWWA C105, Method A as outlined below.***
- 6. ***Polyethylene tubing shall be approximately two (2) feet longer than the length of the pipe section to provide a one (1) foot overlap on each adjacent pipe section. Any rips, punctures, or other damage to the polyethylene shall be repaired with adhesive tape or with a short length of polyethylene tube cut open, wrapped around the pipe and secured with adhesive tape.***
- 7. ***Appurtenances such as bends, reducers and offsets shall be covered with polyethylene in the same manner as the pipe. Odd-shaped appurtenances such as valves, tees, and crosses, which cannot be wrapped in a tube, shall be***

*wrapped with a flat sheet or split length of polyethylene tube. The sheet shall be passed under the appurtenance and brought up around the body. Seams shall be made by bringing the edges together, folding them over twice, and taping them down. Polyethylene shall be securely taped in place at overlaps, valve stems and other penetrations.*

8. *Openings for branches, serve taps, air valves and similar appurtenances shall be made by making an x-shaped cut in the polyethylene and temporarily folding the film back. After the appurtenance is installed, tape the slack film securely to the appurtenance and repair the cut as well as any other damaged areas in the polyethylene with tape.*
9. *When joining with unwrapped pipe, extend the polyethylene tube to cover the unwrapped pipe a distance of at least two (2) feet and secure the end with circumferential turns of tape.*

2506.4 Casing and Carrier Conduits: Casing and carrier conduits shall be installed at required locations by methods acceptable to the Engineer. Installation of the carrier conduit shall be completed prior to installation of the adjacent portions of the pipeline to allow for adjustments.

1. Casings Types:

- a. Steel Casing Pipe: Steel casing pipe is flexible conduit and shall be designed to conform with one of the following design concepts (other methods may be submitted to the Engineer for approval).
  - (1) Method A: The steel conduit is considered a temporary construction means for the installation of the carrier conduit; therefore, cathodic and corrosion protection is not required provided that the carrier and its joints are structurally designed to withstand all possible loadings (live, earth and superimposed) which would otherwise be supported by the casing conduit, and to withstand all pressures necessary to install the required grout. All exterior voids around the casing conduits shall be filled with casing conduit grout (2503.6). Interior void between the carrier and casing conduits shall be filled with sand conforming to Section 2510.3.6. Sand shall be applied under pressure to fill all of the voids without adversely affecting the carrier conduit, joints, alignment and grade.

Method B: The steel casing conduit is considered a permanent installation to protect the carrier conduit and to support all loads, therefore, cathodic and corrosion protection and watertight removable end seals are required for the casing conduit. Care shall be exercised to prevent the carrier conduit from floating and receiving any load transfer from the casing conduit unless it is designed for such loading. The void between casing and carrier conduits shall be treated as shown on the drawings. Cathodic and corrosion protection for method B shall be provided by two magnesium anodes, one at each end of the casing pipe, with a lead wire connected to the encasement pipe by thermite welding.

- b. Reinforced Concrete Casing Pipe: Reinforced concrete casing pipe is a rigid conduit and shall be installed in accordance with recommended procedures in the latest printing of the Concrete Pipe Design Manual prepared by American Concrete Pipe Association.
2. Casing Installation: Installation of casing shall be supervised by a foreman experienced in such work. Casing shall be installed by a combination of auguring and jacking. Alignment and gradient shall be such that the carrier conduit can be installed to line and grade shown on the drawings.

Welding shall be performed by a person experienced with the type of welding necessary. All welds shall conform to AWWA C 206.

3. Liner Plate Installation: Liner plates shall be assembled immediately following the excavation. Advance liner plates or casing continuously with excavation. All voids between liner and surrounding earth shall be filled with casing conduit grout forced in under pressure. As the pumping through any hole is completed, it shall be plugged to prevent the back-flow of grout. After lining installation is complete, it shall be cleaned of all debris and all leaks sealed.
4. Carrier Conduit Installation: After completion of the installation of the casing, the carrier conduit shall be carefully pushed or pulled through the casing in a manner that will maintain proper jointing of the pipe joints and provide required gradient and alignment. Pipe skids shall be provided as indicated on the Plans. The skids shall be securely strapped to the pipe with steel strapping material at least three-quarters (3/4) inch wide.

6. Backfill material shall be carefully placed to avoid damage to or displacement of the pipe and other exposed utilities or structures.
7. Backfill shall not be placed when material contains frost, is frozen, or a blanket of snow prevents proper compaction. Contractor shall remove waste material, trees, organic material, rubbish, or other deleterious substances.
8. No rock whose greatest dimension exceeds six inches shall be placed within two (2) feet to the top of the pipe in any excavation as backfill. No rock greater than one foot in its largest axis shall be placed in any trench excavation as backfill.

**2507.3 Backfilling In Street or Alley Under Pavement:**

**General: All trenches and excavations shall be backfilled with suitable material placed and compacted in conformance with this Section and Section 2102.9 entitled "Embankment."**

*The bedding material area identified as Zone "A" in Figures "1" through "3" in this Section shall consist of approved granular material for all sewer conduits. The bedding rock shall be consolidated by vibratory or manual "chinking" action to provide uniform support – beneath and up to the Springline of the conduit.*

*In the areas above Zone "A", the placement, consolidation, compaction, and moisture content of all backfill materials shall be done in accordance with the following specifications and cross-section details of Figures "1 thru 3." Controlled low strength material (CLSM), or flowable fill as it is commonly known, shall be used for all trenches under street or alley pavements unless otherwise approved by Engineer. The pavement subgrade is a six to twelve-inch thick layer that consists of uniformly compacted material (as specified in Section 5200 and the Standard Drawings). Compaction tests shall be performed, at the Contractors expense, by an approved testing laboratory to ensure the compaction requirements are met. One compaction test will be done for every 20', or part thereof, of trench under pavement and one set of tests will be done for every three feet in depth, or part thereof, of backfill placed. A copy of the compaction test results shall be provided to the City prior to final inspection. Compaction testing is not required on flowable fill.*

*Figure 1: The cross-sectional details in Figure "1" describe the minimum requirements for trench backfilling in areas within street and alley pavements that are located in areas where heavy compaction equipment is utilized. The backfill shall be placed in accordance with section 2102.9.*

*Figure 2: The cross-sectional details in Figure "2" describe the minimum requirements for trench backfilling in areas within street and alley pavements that do not allow for placement of the backfill material in accordance with 2102.9.*

*Figure 3: The cross-sectional detail of Figure "3" prescribes the minimum requirements for trench backfilling in areas that are outside of street and alley pavements.*

1. Backfilling under street and alley pavements in areas where heavy compaction equipment is utilized.  
Backfilling shall be placed as shown in *Figure 1*.

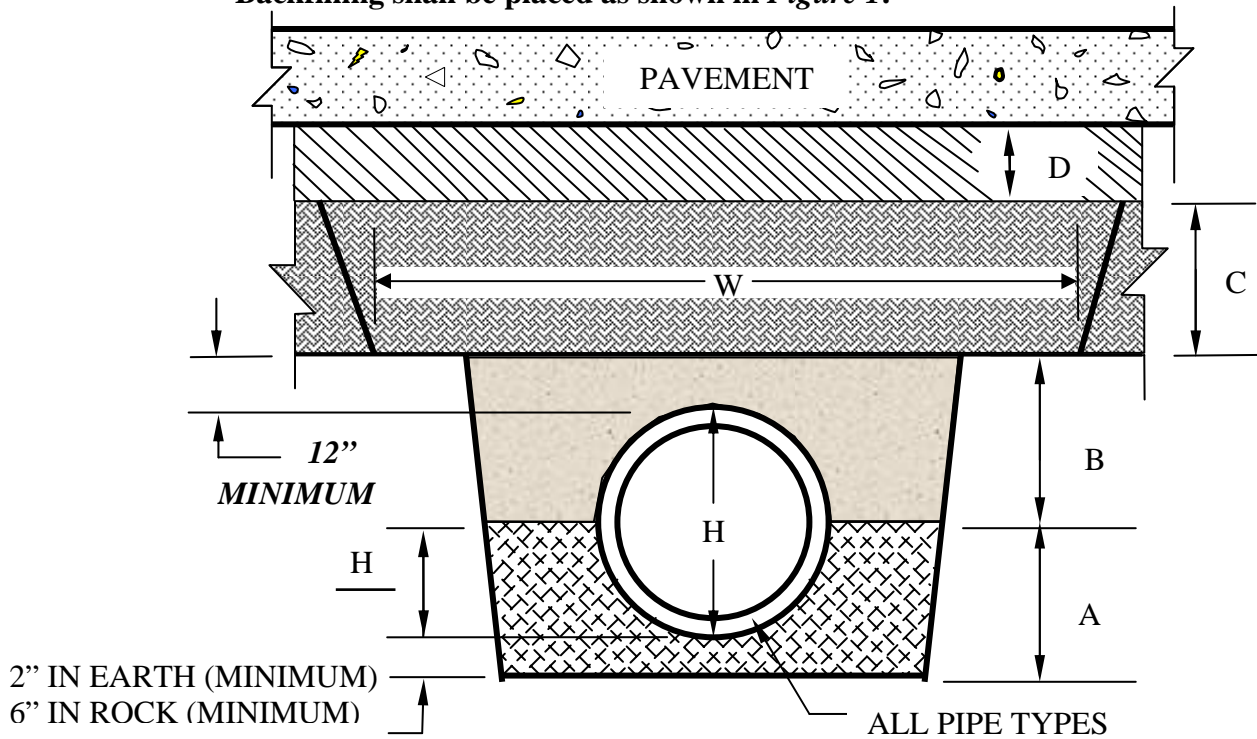

**A – Consolidated granular bedding material or flowable fill.** This zone may be extended up to a maximum of 12" above the top of the pipe if compacted in accordance with Section 2102.9 and tested as described previously.

**B – Flowable Fill (CLSM).** If zone A is extended to encompass zone B then no flowable fill will be required.

**C – Compacted Embankment** - Shall be constructed in accordance with Section 2102.9. Lift thickness shall not exceed the capability of the equipment being utilized to achieve the proper density and consolidation, and in no case shall a lift exceed twelve inches for soil. The minimum width, W, shall be two feet wider than the width of the required compaction device.

**D – Compacted Subgrade** - Subgrade thickness shall be as specified in Table 1 of Section 5206 and as directed by the engineer. Subgrade preparation shall be done in accordance with Section 2201 and shall consist of untreated compacted aggregate, stabilized aggregate base, or compacted soil – in accordance with the associated Sections 2201, 2202, and 2203.

### **FIGURE 1**

*(Sewer Lines Using Earth Compaction Equipment)*

2. The following cross-sectional view of typical sewer trench construction under street and alley pavements, Figure 2, shall apply to all sewer backfill areas where trenches are not widened to allow heavy roadway compaction equipment.:

Backfilling shall be placed as shown in *Figure 2*.

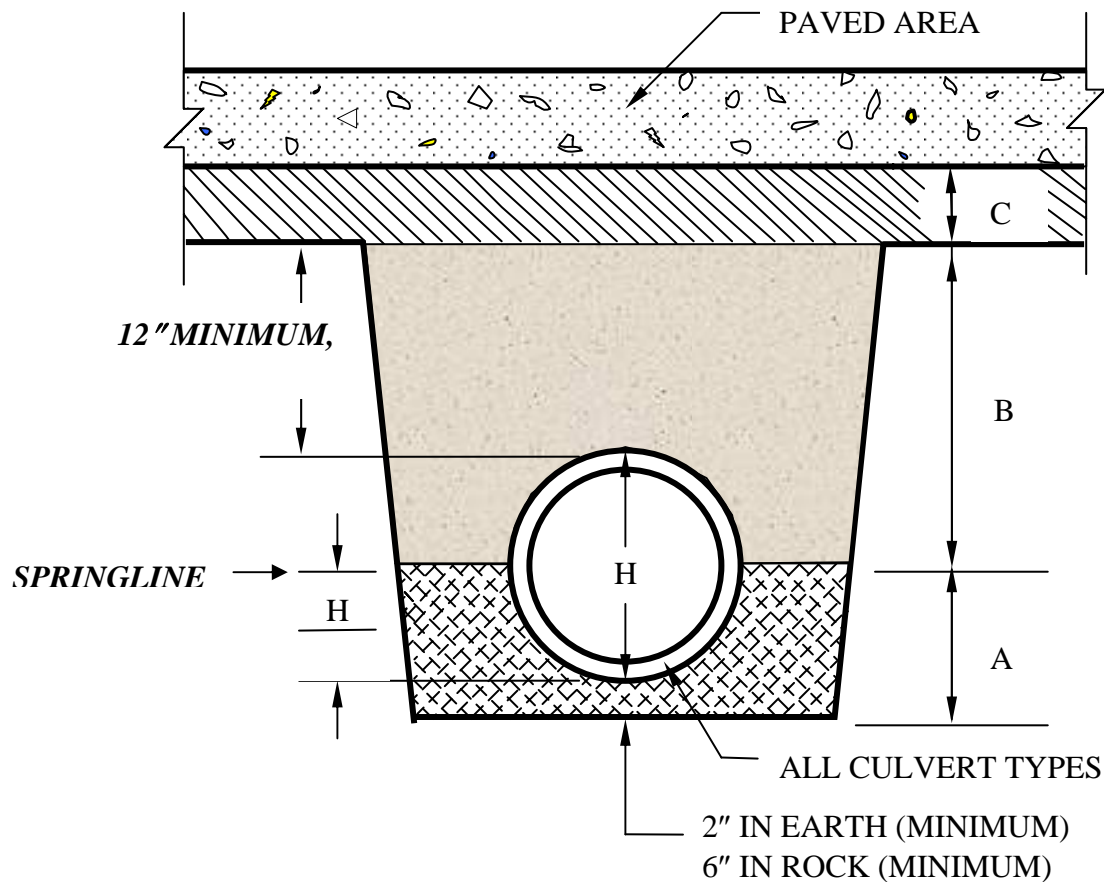

**A – Consolidated granular bedding material.**

**B – Flowable Fill (CLSM).**

**C – Compacted Subgrade - Subgrade thickness shall be as specified in Table 1 of Section 5206 and as directed by the engineer. Subgrade preparation shall be done in accordance with Section 2201, and shall consist of untreated compacted aggregate, stabilized aggregate base, or compacted soil – in accordance with the associated Sections 2201, 2202, and 2203.**

**FIGURE 2**  
**(For Trenches Without Roadway Compaction Equipment)**

3. Trench backfilling in areas other than street and alley pavements where the near edge of trench is behind the back of curb: Backfilling shall be placed as shown in *Figure 3*.

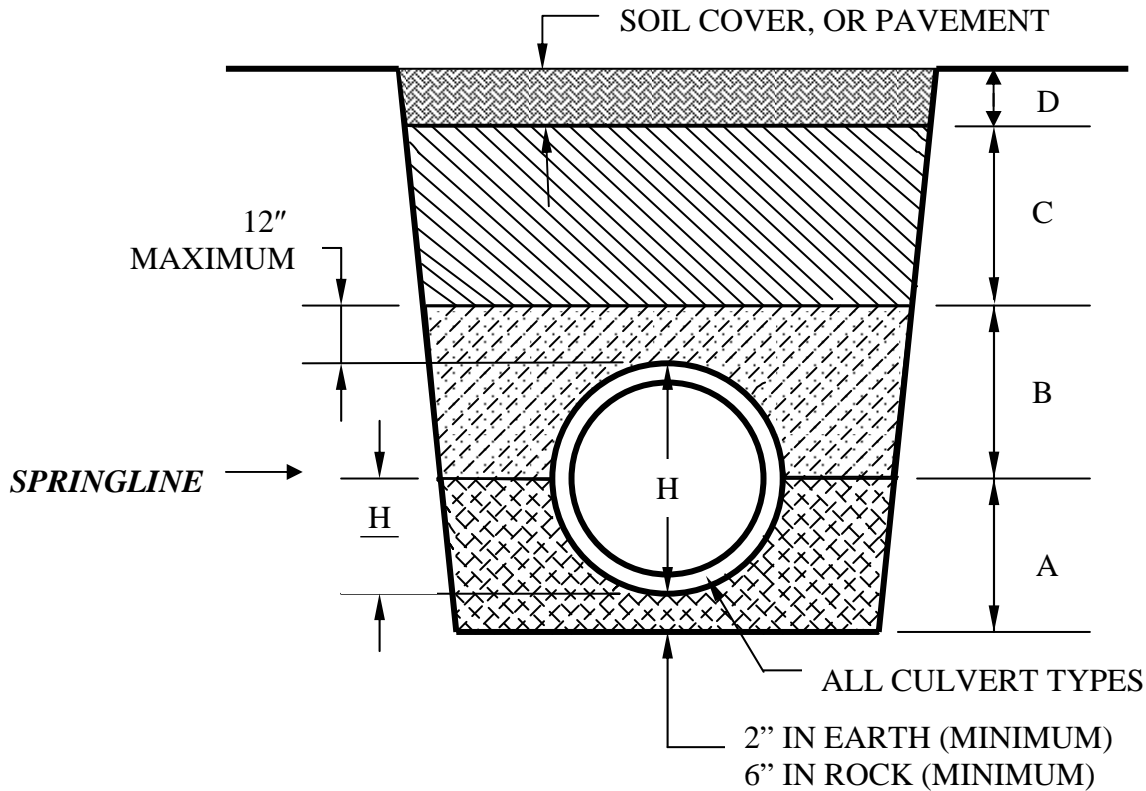

A – Consolidated granular bedding material.

B – Consolidated granular bedding material, flowable fill (CLSM), or compacted soil – compacted to 90% of maximum density using ASTM D 698. Maximum lift thickness for the granular or soil materials shall be six inches.

C – Untreated compacted aggregate, flowable fill (CLSM), or compacted soil – compact to approximate density of adjacent soil but not less than 90% of maximum density using ASTM D 698, except in the Central Business District, as defined in section 2209.2, where untreated compacted aggregate shall not be used. Lift thickness shall not exceed the capability of the equipment being utilized to achieve the proper density and consolidation; however, in no case shall it exceed twenty-four inches for soil.

D – Soil Cover – Soil cover shall be as specified in Section 2102.7. The top twelve inches shall be consolidated soil; the top six inches shall be topsoil suitable for sustaining grass.

**FIGURE 3**  
(Trenches Outside of Street Pavements)

2507.4 Backfilling In Areas Other Than Street or Alley Right-of-Way:

From the top of the pipe embedment (as defined in Section 2506.2.7.b.) to a point at grade the backfill material shall be compacted to no less than 90% of maximum density at optimum moisture plus or minus 2% as determined by ASTM 698.

2507.5 Backfill Around Structures:

1. No backfill shall be placed over or around any structure until the concrete or mortar has attained a minimum strength of 2000 psi and can sufficiently support the loads imposed by the backfill without damage.
2. The Contractor shall use utmost care to avoid any wedging action between the side of the excavation and the structure that would cause any movement of the structure. Any damage caused by premature or unbalanced backfill or by the use of equipment on or near a structure will be the responsibility of the Contractor.
3. No rock larger than four (4) inches maximum dimension shall be placed within one (1) foot of the exterior surface of any structure.
4. ***Backfill around structures in street or alley right-of-way from the bottom of the structure to the bottom of the subgrade shall meet the requirements of 2507.3.***

SECTION 2508 Restoration:

2508.1 Scope: This section covers all work required in surface restoration on private and public properties that are disturbed by construction.

2508.2 General: The Contractor shall restore the project site to conditions equal to or better than those existing prior to entry unless otherwise specified.

1. Maintain adequate safety signs, barricades and lights until final restoration of work area is completed.
2. Public property shall be restored to the requirements of the public body having jurisdiction.

2508.3 Clean-Up: The Contractor, upon completion of installation and backfill operations, shall prepare the area for final grading including but not limited to the following items:

1. Clean-up shall follow the backfilling operations as closely as possible.
2. Excess material shall be removed from the site including material that has washed into the stream beds, storm water facilities, streets, etc.
3. Tools, equipment and construction material shall be removed except for in designated storage areas along the pipeline route.
4. Restore surface and sub-surface drainage and provide temporary wash checks where necessary.

2508.4 Finished Grading: The Contractor shall finish grade the area to lines and grades shown on the Plans or if not shown to those that existed prior to the area being disturbed. Special attention shall be directed to assure surface drainage. The area shall be smoothed by raking or dragging.

2508.5 Seeding: The requirements set forth under Section 2401 – Seeding shall be used as if fully written herein.

2508.6 Sodding: The requirements set forth under Section 2402 – Sodding shall be used as if fully written herein.

2508.7 Pavement Replacement:

1. Scope: This section covers the furnishing of all labor, equipment, tools and materials in the performance of all work for the replacement of pavement including sidewalks, driveways and curbing as shown on the Plans and in the Special Provisions.

and then connecting a clear plastic tube to pipe nipple. The hose shall be held vertically and a measurement of height in feet of water shall be taken after the water stops rising in this plastic tube. The height in feet shall be divided by 2.3 to establish the pounds of pressure that will be added to all readings.

2509.5 Deflection Test:

1. General: Flexible pipelines shall be tested for deflection by pulling a mandrel through the entire length thereof.
  - a. The mandrel (go/no-go) device shall be cylindrical in shape and constructed with nine (9) evenly spaced arms or prongs. Mandrels with fewer arms will be rejected as not sufficiently accurate. The dimensions of the mandrel shall be as listed in the accompanying table. The “D” mandrel dimension shall carry a tolerance of + or – 0.01 inch. Allowances for pipe wall thickness tolerances or ovality (from heat, shipping, poor production, etc.) shall not be deducted from the “D” dimension but shall be counted in as a part of the five (5) percent or lesser deflection allowance. Contact length (L) shall be measured between points of contact on the mandrel arms. The length shall not be less than as shown in the accompanying table.
  - b. The Engineer shall be responsible for approving the mandrel. Proving rings shall be used to verify this.
  - c. The mandrel shall be hand pulled without any mechanical assistance, by one of the Contractor’s personnel through all flexible sewer lines. Any sections of sewer not passing the mandrel test shall be uncovered and the Contractor, at no additional cost to the Owner, shall re-bed or replace the sewer to the satisfaction of the Engineer. These repaired sections shall be re-tested.
  - d. *The testing shall be conducted after final trench backfill.*

*D and L Dimensions for 9 Arm Mandrel*

<i>Nominal Diameter</i>	<i>L(Min)</i>	<i>ASTM 3034 SDR26</i>	<i>ASTM 2214 SDR21</i>	<i>ASTM 679 T-1 Wall</i>
8”	8”	7.37”	7.41”	-----
10”	10”	9.21”	9.24”	-----
12”	12”	10.96”	10.96”	-----
15”	15”	13.42”	-----	-----
18”	18”	-----	15.47”	16.76”
21”	21”	-----	-----	19.74”
24”	24”	-----	20.63”	22.21”
27”	27”	-----	-----	25.03”

*The above dimensions were determined using the following formula: .95X (average O.D. – 2 x min. wall thickness)*

special junction structures, metering stations and similar structures constructed on the pipeline.

***Manholes and special structures may be constructed of precast concrete sections or cast-in-place concrete.***

### 2510.3 Manhole Materials:

1. Brick shall conform to ASTM C 32, Grade SS or SM, nominal size 2 ¼ x 4x8 inches. For grade SM, the maximum water absorption by five (5) hour boiling shall not exceed twelve (12) percent per individual brick or nine (9) percent for the average of five (5) bricks.
2. Mortar and plaster coating: Mortar and plaster coatings for masonry manhole units shall conform to ASTM C 270. The mix shall consist of two (2) parts Portland cement to one (1) part masonry cement to six (6) parts standard plaster sand. No mortar or plaster mixed more than thirty (30) minutes shall be incorporated in the work.
3. Non-Shrink Grout: Non-shrink grout shall be in the plastic state and show no expansion after set as tested in accordance with ASTM C 827 and shall develop compressive strength not less than three thousand (3,000) pounds per square inch with a trowelable mix within twenty-four (24) hours per ASTM C 109. The placement time shall be not less than forty-five (45) minutes based on initial set per ASTM C 191.
4. Waterproofing: Waterproofing shall be a coal-tar coating and conform to ASTM D 450. Exterior surfaces shall be coated with Tnemec “46-450 Heavy Tnemecol” or approved equal. Where specified, interior surfaces (which are exposed to raw sewage and sulfide gases) shall be coated with Tnemec “45-449 Heavy Duty Black” or approved equal. The minimum dry thickness for all waterproofing shall be 14.0 mils.
5. Precast Concrete: Precast concrete manholes shall conform to ASTM C 478 with the following modifications.
  - a. ***Wall thickness not less than one-twelfth (1/12) of inside diameter plus one (1) inch or five (5) inches, whichever is greater.***
  - b. Cement, Fine Aggregate, Coarse Aggregate and Water used in the manufacture of precast manholes shall be as specified in Section 2510.3.6.
  - c. Developed bases shall be used where practical. The diameter of the base pad shall be eight (8) inches greater than outside diameter of the manhole.

- d. Pipe openings shall be circular or horseshoe shaped with surfaces grooved or textured to improve mortar bond. Flexible gaskets shall be used with developed base manholes. Flexible gaskets shall be Press-wedge, A-Lock, or approved equal.
  - e. The minimum distance from the invert of the downstream pipe to the top surface of the base shall be three (3) inches.
  - f. Joints between manhole sections, adjustment rings, and below the ring and cover shall be sealed with preformed bitumastic sealants, Kent-Seal, Ram-Nek, E-Z Stick or approved equal. The minimum bead dimension shall be one inch.
  - g. ***Both the bell and spigot ends of the manhole sections shall be primed with a liquid primer that is compatible with the bitumastic sealants, Kent-Seal, Ram-Nek, E-Z Stick or approved equal.***
  - h. ***Reducing sections may be used at six (6) feet or more above the invert.***
  - i. ***Eccentric cone sections shall be used unless noted otherwise on the project plans.***
6. Manhole and Special Concrete: Manhole and special concrete shall conform to “The Mid-West Concrete Industry Board Incorporated” (MCIB) Specifications and to the requirements therein for the MCIB Mix Number specified on the drawings or as provided herein.
- a. ***Standard Concrete: Standard concrete used for concrete encasements and embedments, thrust blocks, pipe anchors, pipe collars, etc. shall be MCIB Mix Number A 480-1-4-0.542, unless otherwise specified.***
  - b. ***Structural Concrete: Structural concrete used for aerial crossing piers, wetwell walls, manhole walls, bases, inverts, and flat slabs, etc. shall be MCIB Mix Number A 558-1-2-0.421, unless otherwise specified.***
  - c. Admixtures: Air-entraining admixtures shall provide an air content within the range of 4 ½ to 7 ½ percent by volume as measured by the pressure method (ASMT C 231). The air entraining admixtures shall meet the requirements of ASTM C 260.
  - d. Portland Cement: Portland cement shall conform to ASTM C 150 Type I. Where high early strength is desired, Type III can be used.
  - e. Fine Aggregate: Fine aggregate shall be clean, natural sand meeting the requirements of ASTM C 33. Grading shall be within the limits as set forth by MCIB.
  - f. Coarse Aggregate: Coarse aggregate shall be limestone meeting the requirements of ASTM C 33. The sum total of all deleterious material shall not exceed the requirements of ASTM C 33.
  - g. Water: Water shall be clean and free from deleterious substances. Only potable water will be acceptable without testing.

7. Reinforcement steel: Reinforcement steel shall conform to the following minimum requirements.
  - a. Design: Reinforcing steel shall conform to one of the following.
    - (1) Welded Wire Fabric – ASTM A 185.
    - (2) Reinforcing Bars – ASTM A 615, Grade 40 or Grade 60.
    - (3) Fabricated Steel Bar and Rod Mats – ASTM A 184, Grade 40 or Grade 60.
  - b. Fabricating Tolerances: Tolerances for concrete reinforcement shall conform to the following requirements.
    - (1) Sheared length = +/- 1 inch.
    - (2) Stirrups, ties, and spiral = +/- 2 inches.
    - (3) <sup>(10/1/05)</sup> All other bends = +/- 1 inch.
8. ***Iron Castings: Casting shall conform to the requirements of ASTM A 48, Class 35 B, ASHTO M306 and KCMO Standard MH-RC. Castings shall be clean and without surface defects which will impair serviceability. Plugging or filling of holes or other defects will not be permitted. Parting fins and pouring gates shall be removed.***
  - a. ***Rings and Covers: Rings and covers shall meet the following minimum requirements and Kansas City Standard MH-RC.***
    - (1) ***Cam lock covers shall not be placed in roadway pavement unless shown on the plans or directed by the engineer. All other covers shall be cam lock. All covers shall have provisions for opening, such as concealed pick holes.***
    - (2) ***Bearing surfaces between the ring and cover shall be machine finished or ground to assure interchangeability and non-rocking fit in any position.***
    - (3) ***Bolt-down type manhole rings shall be anchored to the manhole walls with not less than four (4) three-fourths (3/4) inch (M18x2.5) diameter steel bolts embedded a minimum of four (4) inches, (100 mm), plus or minus one half (1/2) inch, (10 mm), into the cone section of the manhole, except where the entire ring is embedded in a concrete top slab.***
    - (4) ***Bolt-down manhole rings and their covers shall be provided with machined surfaces, O-ring or T-ring gaskets and cam locks. Cam lock bolt heads shall fit flush or below the top of the cover. The O-ring or T-ring rubber gasket shall be neoprene or other synthetic material, sixty (60) plus or minus five (5) hardness when measured by ASTM D 2240 type durometer.***

***(5) All manhole rings and covers placed in paved areas shall be adjustable to meet any slope and grade of the roadway, from 0 to 17%, and shall be able to be raised and lowered in ¼ inch increments, up to 2¾ inches. Ring height must be adjustable after installation without disturbing the surrounding pavement. The ring and lid shall be rated for H20 traffic.***

**Steps:**

**(5) Cast-Iron Steps: Cast iron steps are not allowed.**

(6) Steel core, plastic coated steps: Steel core plastic coated steps shall meet the following minimum requirements.

- a. The plastic coating shall be a copolymer polypropylene meeting ASTM D 4101.
- b. The steel core shall be a minimum of ½ inch in diameter and grade 60.
- c. The requirements of ASTM C 478 shall be met except minimum pull-out strength shall be 1000 pounds.

9. **Joint sealing systems.**

a. **Exterior: Heat shrinkable joint wrap shall conform to ANSI/AWWA C216-89. The wrap system shall consist of a two-part material (backing + adhesive) with a closure system and a G-type primer. It shall consist of an irradiated cross-linked polyolefin sheeting, pre-coated with a layer of anti-corrosion adhesive. The backing shall have a minimum recovery of 22%. The adhesive shall be a mastic-type, specially formulated to become fluid at temperatures achieved during installation and maintain flexibility in cold climates with installation temperatures down to -40°F. Upon cooling the adhesive shall form a tough, elastomeric protective layer. The wrap shall employ a closure seal to allow sealing of the overlap area. The overall thickness of an applied sleeve shall nominally measure 0.100 inches (2.5 mm). (Wrapid Seal as manufactures by Canusa and Riser-Wrap as manufactured by Pipeline Seal & Insulater, inc. has been approved.)**

b. **Internal: All internal sealing materials shall be able to withstand hydrogen sulfide and other corrosive gases, and shall be approved by the engineer before bidding.**

**(1) Rubber Seal Systems: Internal flexible rubber sleeve, extensions and wedge strips shall be extruded or molded from a high grade rubber compound conforming to the applicable requirements of ASTM C 923, with a minimum 1500 psi tensile strength, maximum 18% compression set and a hardness (durometer) or 48 +or- 5. (Cretex Specialty Products system has been approved).**

**Sleeves shall be either double or triple pleated with a minimum unexpanded vertical height of 8" and 10" respectively, a minimum thickness of 3/16" and shall be capable of a vertical expansion when installed of not less than 2". The top and bottom section of the sleeve shall contain an integrally formed expansion band recess and multiple sealing fins.**

**Extensions shall have a minimum thickness of 3/16". The top section of the extension shall be shaped to fit into the bottom band recess of the sleeve under**

*the bottom chimney seal band. The bottom section of the extension shall contain an integrally formed expansion band recess and multiple sealing fins matching that of the rubber sleeve.*

*Splices used to fabricate the sleeve and extension shall be hot vulcanized and be strong enough to withstand a 180 degree bend with no visible separation.*

- (2) *Barrier Seal Systems: Barrier seal systems shall be of an impermeable material such as ASTM D 148 polyethylene, with a UV inhibitor for above ground applications that will carry an AASHTO M-306 proof load of 25,000 pounds.*

10. *Flexible gaskets*

*1. Flexible gaskets shall conform to the requirements of ASTM C923 and the type of pipe used. PSX and ALOK gaskets are approved and ALOK X-CEL gaskets are approved for 8, 10 and 12 inch pipes. For fifteen (15) inch pipe and larger, flexible water-stop gaskets conforming to the requirements of ASTM C923 may be used.*

11. *Mastic Filler*

*1. Mastic filler shall be a butyl rubber material meeting ASTM C 990 and AASHTO M-198 and be compatible with all material that it contacts (i.e. Wrapid Seal, PRO-STIK or an approved equal).*

12. *Manhole Adjustment Rings: Rings shall be constructed of concrete, HDPE, or recycled rubber.*

*If HDPE adjustment rings are used, they shall be injection molded-recycled HDPE, as manufactured by LADTECH, Inc. or approved equal. They shall be installed as per the manufacture's recommendations.*

*If recycled rubber adjustment rings are used, they shall consist of no less than 80%, by weight, recycled rubber and no less than 10% by volume shredded fiber as manufactured by GNR Technologies or approved equal. They shall be installed as per manufacture's recommendations.*

*The top and bottom of all adjustment rings shall be sealed using a mastic filler meeting the requirements of 2510.3.11 or an epoxy paste. The epoxy paste shall be two component, moistures insensitive, containing no solvents, and capable of bonding with all materials it is to be used on, like Epoxytec Micor C.P.P. or approved equal.*

2510.4 Manhole Site Preparation: Manhole site preparation shall be governed by Section 2504.

#### 2510.5 Manhole Excavation

1. Excavation: Excavation for manholes and special structures shall be governed by this Section and Section 2505. It shall be achieved in a suitable and orderly manner providing a minimum disturbance to the general public.
2. Depth of Excavation: Depth of excavation shall be that required for proper installation of the manhole or structure. Over-depth excavation may be required by the Engineer if the subgrade is unstable. Over-depth excavation due to unstable subgrade shall be backfilled as required by the Engineer. Over-depth excavation occurring through an oversight by the Contractor shall be backfilled as required by the Engineer at no additional cost to the Owner.
3. Side Clearances: Side clearances outside the manhole and/or structures shall be no greater than to allow for forming, connection of piping, proper application of special coatings, if required, and to permit inspection. When concrete is to be placed directly against excavated faces, excavation shall be sufficiently outside of the manhole or structure to provide not less than three (3) inches of concrete cover over the steel reinforcement.

2510.6 Manhole Installation: Manhole installation shall be governed by this Section and Section 2506. It shall be performed by the Contractor on a schedule that will provide an orderly progression of the work.

1. Bases:
  - a. Precast developed bases shall be reinforced in accordance with ASTM C478.
  - b. If preferred developed bases are not used, poured concrete bases shall be used. Developed bases shall be installed on a maximum of 4 inches of crushed rock. Depths exceeding this amount shall be filled with mass concrete.
  - c. Poured-in-place bases shall have a minimum thickness of eight (8) inches. When poured-in-place bases are used, the invert shall be poured monolithically with the base. The bottom wall sections shall be embedded in the base section a minimum of three (3) inches. The bottom precast wall section shall not be set upon a previously poured base. Solid concrete blocks shall be used for supporting and leveling the wall section prior to pouring the base.

***Base thickness may be reduced to six (6) inches when it is poured on solid rock which meets the approval of the Engineer.***
  - d. ***Poured-in-place bases shall extend to the first joint from the manhole when reinforced concrete and vitrified clay pipe is used without flexible joints as specified in Sections 2503.2.7.c and 2503.2.8.b.***
2. Inside Dimensions: The minimum horizontal clear distance in the barrel of the manholes shall not be less than four feet unless otherwise specified on the plans.
3. ***Brick shall not be used for new manhole construction.***

4. Precast:
- a. Delivery: Precast concrete components shall not be delivered to the job until representative concrete control cylinders have attained at least 80 percent of the specified minimum design strength
  - b. ***Inspection: Precast concrete shall be inspected at the manufacturer prior to delivery to the job site. Rejection of defective or cracked precast concrete components shall be in accordance with ASTM C478.***
  - c. Wall Thickness: Wall thickness shall conform to the requirements of Section 2510.3.5.
  - d. ***Construction: Precast sections shall be cleaned of all dirt, grass, and other deleterious matter. Seal each joint of adjustments rings and castings with a double bead of pre-formed bitumastic joint sealant. Sections shall be placed such that steps are aligned but without rotation or damage to sealant integrity. Lift holes and the area between the pipe and the precast sections, when flexible gaskets are not used, shall be patched with non-shrink grout.***
  - e. ***Waterproofing: A coal-tar coating, in accordance with paragraph 2510.3.4., shall be applied to the exterior of all precast manhole sections, flat-top sections and adjustment rings. The coating shall be made after the inspection and approval of the manhole sections and adjustment rings by the Public Works Engineering Division materials and testing laboratory. Backfill shall not be made until the coating has cured.***
5. Cast-In-Place:
- a. Wall Thickness: Wall thickness shall conform to the dimensions as shown on the drawings.
  - b. Construction: Reinforcement steel shall be placed as shown on the drawing. Tie-holes shall be patched with non-shrink grout. Wall sleeves, where required, shall be installed as shown on the drawings. Water stops shall be installed at the wall and slab connection and shall be of the size, thickness and material as shown on the drawings.
  - c. Waterproofing: Interior protective coatings, where required, shall conform to the material specifications. Application shall conform to the manufacturer's recommendation.

- d. Waterproofing: Interior protective coatings, where required, shall conform to the material specifications. Application shall conform to the manufacturer's recommendation.
- 6. Top Slabs: Thickness shall conform to the dimensions and reinforcement steel shall be placed as shown on the drawings.
- 7. Pipe Stubs: Stubs shall be installed at the locations, angles, elevations and of the materials shown on the drawings. A water-tight removable stopper shall be installed in each pipe stub. Pipe stubs shall be installed so that a pipe joint will be two (2) feet or less from the outside manhole wall.

8. ***Inverts: Inverts shall be structural concrete steel-troweled to produce a dense, smooth finish and joint with the square cut end of the pipes. The outside wall of the pipe at the springline shall extend to the inside wall of the manhole, but shall not project more than 1 inch beyond the wall. The invert channel shall be "U" shaped in cross section and extend upward one-half of the inside pipe diameter if the pipe diameter is less than eighteen (18) inches. If the pipe diameter is eighteen (18) inches or greater, the "U" shaped invert shall extend upward for the full inside pipe diameter.***
9. Steps: Steps shall be aligned vertically below the casting and spaced at sixteen (16) inch centers. The top step shall be not more than one (1) foot below the top of the cone. The lowest step shall be not more than two (2) feet above the invert bench. Field-drilled step holes are not permitted in precast concrete manholes.
10. Top Elevation: The finished top elevation of manhole castings shall conform to the following unless otherwise shown on the plans or directed by the Engineer.
  - a. In paved or future paved areas, the top of the casting shall conform to the slope of the pavement and be 1/8 inch below the finished pavement elevation.
  - b. In non-pavement areas, the top of the casting shall be not more than six (6) inches above the surrounding ground nor less than the sod's upper root limit. The final elevation shall be at a point where water will not pond over the manhole cover.
11. Manhole Adjustment: All new manholes will be provided with adjustment ring(s) underneath the casting as shown on Plans. The joints shall be sealed with preformed bitumastic sealant. The maximum allowable adjustment distance between the top of the cone and the bottom of the casting shall be 12". If the top of an existing manhole is required to be raised to an elevation that will exceed the maximum adjustment distance or lowered more than the adjustment rings will allow, all vertical adjustments shall be made to the barrel of the manhole.
12. Castings: Castings shall be installed with the mud ring inserted inside the manhole opening and resting on a minimum of two rows of preformed bitumastic sealer. Bolt-down castings shall be held in place as shown on the plans.
13. Joint Sealing Systems:
  - a. ***External Joint Sealing Systems:***
    - (1) ***Adjustment rings and manhole joints below the surface of the ground shall be covered with heat shrinkable joint wrap and shall be installed in accordance with AWWA C-206. Manhole surface to be covered shall be free of dirt, sharp points and preheated to remove moisture. Primer shall be applied over entire area to be covered and let dry (5-15 minutes).***

***Wrap shall be cut twelve (12) inches longer than the exterior circumference of the manhole, or as recommended by manufacturer. The wrap shall extend six (6) inches above and below each joint and the wrap at the cone section and casting shall be a minimum of eighteen (18) inches wide.***

***Place wrap around the manhole and position the self-adhering closure seal at the overlap. Heat the overlap area and pat down with a gloved hand to ensure bonding. Then continue heating until the entire wrap has recovered. Smooth out the wrinkles and allow the adhesive to set by quenching with water or allowing to air cool prior to backfilling.***

***(2). Adjustment rings and manhole joints above the surface of the ground shall be covered with an adhesive wrap of elastomeric and/or rubber materials (minimum thickness 0.065 inches) as approved by the engineer. The wrap shall overlap the joint between the bottom of the casting and the upper adjustment ring and be continuous to the joint between the lower ring and manhole. The minimum overlap of a manhole joint shall be six (6) inches. The minimum overlap at each casting shall be one (1) inch. The surface of the adjustment rings and all manhole joints shall be primed in accordance with the manufacturer's recommendations***

b. Internal Joint Sealing Systems:

Adjustment rings may be sealed with a barrier seal similar to I/I Barrier manufactured by Strike Products (31785 64<sup>th</sup> Ave, Cannon Falls, MN 55009). Installation shall be in accordance with the manufacturer's recommendation, including the omission on sealant between the I/I Barrier and the bottom adjustment ring.

14. ***Connections to Manhole: All pipe connections to manholes shall be made with flexible gaskets in compliance with paragraph 2510.3.10. and installed as required by the manufacturer.***

2510.7 Manhole Backfilling: Manhole backfilling shall be governed by Section 2507.

2510.8 Restoration: Restoration shall be governed by Section 2508.

2510.9 Manhole Testing:

1. Scope: This section governs the required testing of manholes and structures not otherwise set forth.
2. ***General: All manholes shall be tested for infiltration and inflow.***
3. ***Infiltration and Inflow Testing: All manholes shall be vacuum tested in the presence of the Engineer.***

***The vacuum test shall consist of properly sealing the manhole openings, applying a vacuum equivalent to ten inches of mercury, and measuring the time the manhole will hold an acceptable level of vacuum. The vacuum test shall be performed in accordance with the following procedures:***

- a. ***Each manhole shall be tested after backfilling to, at least, the level of the bottom adjustment ring.***
- b. ***The vacuum test shall include testing of the seal between the cast iron frame and the concrete cone, slab or top adjustment ring.***
- c. ***All pipes entering the manhole shall be plugged at least eight inches into the sewer pipe. The plug must be inflated at a location beyond the manhole/pipe gasket.***
- d. ***All plugs shall be adequately braced to prevent the plug or pipe from being dislodged and drawn into the manhole.***
- e. ***A vacuum of at least ten and one-half inches of mercury shall be drawn on the manhole. Shut the valve on the vacuum line to the manhole and disconnect the vacuum line. Open the vacuum line valve and adjust the vacuum to ten inches of mercury.***
- f. ***The pressure gauge shall be liquid filled having a 3.5 inch diameter face with a reading from zero to thirty inches of mercury. The test equipment shall be capable of having two gauges connected. The gauge supplied with the test equipment shall match the reading of a gauge furnished by the Public Works Department. The gauge reading is to be verified on each project.***
- g. ***The time for the vacuum reading to drop from ten inches of mercury to nine inches of mercury must be equal to or greater than the following values for the manhole to be considered as passing the vacuum test:***

<b><u>Manhole Depth</u></b>	<b><u>Time (minutes)</u></b>
<b><i>10 feet or less</i></b>	<b><i>2</i></b>
<b><i>10.1 to 15 feet</i></b>	<b><i>2.5</i></b>
<b><i>15.1 to 25 feet</i></b>	<b><i>3</i></b>

***h. If a manhole fails the vacuum test, the manhole shall be uncovered and the leak repaired by patching the exterior of the manhole. The manhole shall then be backfilled and re-tested.***

***The vacuum testing of manholes shall be done prior to air testing the sewer lines that enter or exit the manhole.***

2511 Measurements and Payment:

***2511.1 Measurements: The quantities of completed work will be measured in the following units. All quantities shall be field measured unless otherwise specified.***

1. Pipe:
  - a. Open Trenched: Measurement of various size, type and depth of pipe will be to the nearest 0.1 foot for each line between structures and made to the inside face of the connecting structure.
  - b. Tunneled, Bored or Jacked: Measurement will be to the nearest 0.1 foot for the limits of tunneling, boring or jacking as shown on the plans.
  - c. Embedment or Encasement: Concrete embedment or encasement will be measured by the lineal foot of each size and type.
  - d. Manhole: Measurement will be made for the applicable type, size and depth of manhole as listed in the proposal. The depth shall be determined by measuring from the top of the casting to the outlet pipe flow line to the nearest 0.1 foot where applicable.
  - e. Seeding: Measurement will be made in accordance with Section 2403.
  - f. Sodding: Measurement will be made in accordance with Section 2403.